

INFORMATION TECHNOLOGY

Part III



Computer science syllabus for class III

Lesson	Title/Topic of the lesson	No. of Periods
1.	Introduction to Computer <ul style="list-style-type: none"> ➤ Definition ➤ Hardware Vs Software ➤ Characteristics of Computers ➤ Wonders of Computers 	7
2.	Input and Output Devices <ul style="list-style-type: none"> ➤ Input devices–Keyboard, Mouse, Joystick ➤ Output devices–Monitor, Printer, Speakers ➤ Types and Functions of a Keyboard ➤ Types of Printers 	9
3.	Introduction to Software <ul style="list-style-type: none"> ➤ What is a Software? ➤ Types of Software–System and Application ➤ Operating Systems 	6
4.	Memory <ul style="list-style-type: none"> ➤ What is a memory? ➤ Types of memory–Primary and Secondary ➤ RAM and ROM ➤ Memory Units 	8
5.	Multimedia and Internet <ul style="list-style-type: none"> ➤ What is Multimedia? ➤ Components used in multimedia ➤ Play music and video ➤ What is internet? ➤ Websites 	5
6.	MS-Word <ul style="list-style-type: none"> ➤ Menu and commands ➤ Tools–formatting, aligning, editing ➤ Formatting (Font, aligning, size etc.) ➤ Bullets and numbers, Indenting ➤ Creating tables 	7
7.	MS-Paint-Advanced <ul style="list-style-type: none"> ➤ Tools for font, color, eraser, pencil ➤ View menu, Shapes, fill, outline & Colours ➤ Projects–Design of house, nature, machine etc. 	9

8.	Programming with LOGO–Part-1 <ul style="list-style-type: none">➤ Home screen, Turtle➤ Logo commands–Moving, turning, pen, erase➤ Hiding and showing turtle➤ Drawing trigonometric shapes, letters etc.	9
Total Number of periods		60

Content

Lesson	Title/Topic of the lesson	Page No
1.	Introduction to Computer	5
2.	Input and Output devices	12
3.	Introduction to software	21
4.	Memory	25
5.	Multimedia and Internet	29
6.	Ms Word	35
7.	MS Paint- advance	48
8.	Programming with Logo –Part 1	59

CHAPTER – 1

Introduction to Computer

Learning Objectives

Students will be able to:

- Define computer
- Differentiate between hardware and software
- Explain various characteristics of computers



Hello Friends!
Let us learn few more terms related to Computers
in this chapter.

Computer

A Computer is an electronic machine. It runs on electricity. It takes inputs from users. It uses some program (set of instructions) to process these inputs. Finally it delivers output as per your requirement. It can also store your data which you can use later on.



Hardware Vs Software

All the parts of a computer that we can see and touch are called hardware. In other words, hardware are the physical parts of a computer. The basic components of the computer hardware are listed below:

Monitor
Keyboard
Mouse
CPU (Central Processing Unit)
Mother Board
RAM (Random Access Memory)
Hard Disk Drive
Printer

Speaker etc

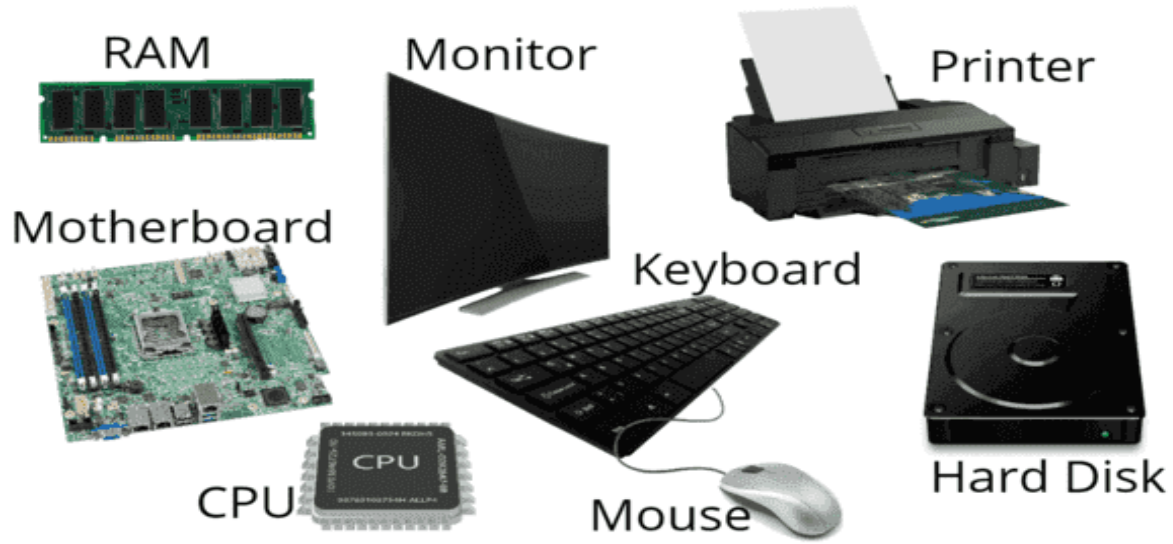

Hardware Components of a Computer

Software is a set of programs or a set of instructions that tell a computer what to do. Software are the logical parts of a computer which we can see or touch.

For example: Windows Operating System, Mac OS, Android, Linux Antivirus, MS Paint, MS Word etc.

Logos of Operating systems



Hardware	Software
Hardware refers to the physical components of a computer that can be seen or touched	Software refers to the logical components of a computer that can not be seen or touched
Hardware wears out over time	Software does not wear out over time
Hardware is tangible	Software is intangible
Examples: Monitor, Keyboard, Mouse, Speakers	Examples: Operating system, MS Paint, MS Word

Characteristics of Computers:

Computers are used in almost every field of the modern world from online teaching to online ticket booking, from banking to satellite launching etc. A computer is capable of performing all these functions due to its characteristics. Some of the key characteristics are as follows:

- Speed
- Accuracy
- Diligence
- Versatility

Storage

1. Speed: – As you know computer can work very fast. It takes only few seconds for calculations that we take hours to complete. You will be surprised to know that computer can perform millions (1,000,000) of instructions and even more per second.

Therefore, we determine the speed of computer in terms of microsecond (10⁻⁶ part of a second) or nanosecond (10⁻⁹ part of a second). From this you can imagine how fast your computer performs work.

2. Accuracy: – The degree of accuracy of computer is very high and every calculation is performed with the same accuracy.

- 3. Diligence: – A computer is free from tiredness, lack of concentration, fatigue, etc. It can work for hours without committing any error. If millions of calculations are to be performed, a computer will perform every

calculation with the same accuracy.

- 4. Versatility: – It means the capacity to perform completely different type of work. You may use your computer to prepare results of your class. Next moment you may use it for booking of tickets or to prepare electric bills.
- 5. Storage: – Computer has the power of storing any amount of information or data. Any information can be stored and recalled as long as you require it, for any numbers of years. The Computer has an in-built memory where it can store a large amount of data. You can also store data in secondary storage devices such as floppy disk, CD, Pen Drive etc. which can be kept outside your computer and can be carried to other computers.

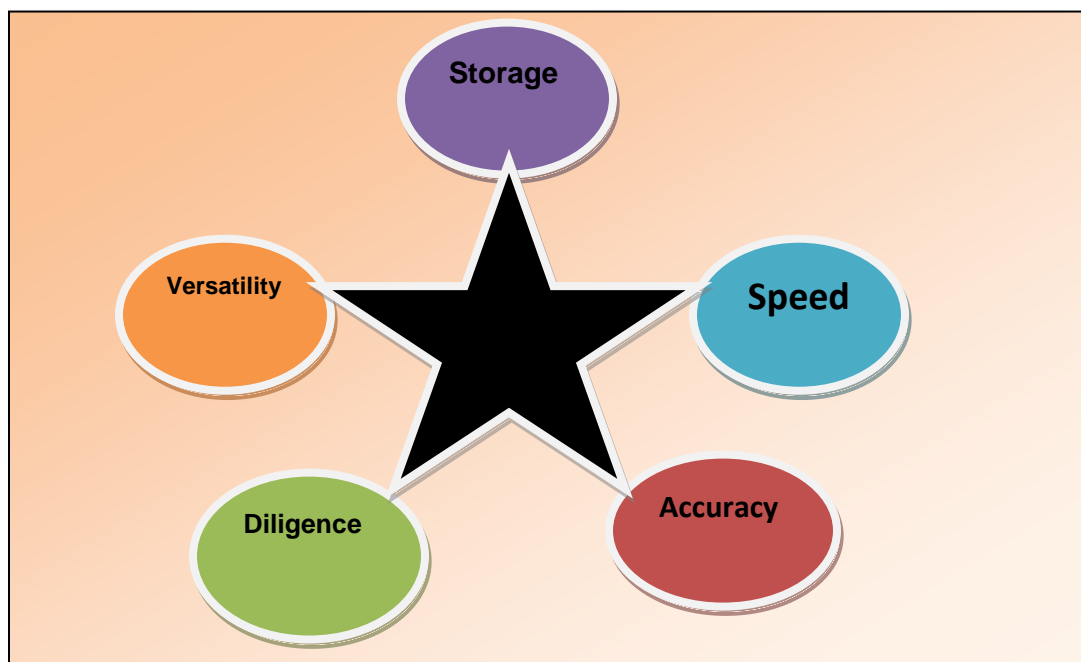

Characteristics of Computers

- Limitations of Computers:
- Although a computer is a wonderful machine but it has certain limitations
- No IQ
- No feelings/ EQ
- Lack of Decision Making

- Lack of Common Sense
- Cannot Implement
- Human dependency

1. No IQ

A computer cannot act on situations that are not fed or programmed into them. They have zero IQ (Intelligent Quotient). These outputs are completely dependent on the user's input. That is they produce the wrong output if the wrong input is provided instead of correcting it. This is why the computer is also called the dump machine.

2. No feelings/ EQ

While the computer can work tirelessly and relentlessly. However, few tasks require suggestions and ideas. This can only be done if a person feels positive, negative, or some feeling toward the task. A computer proves unsuccessful in such scenarios as it does not have feelings/ EQ (Emotional Quotient). This is the biggest limitation of the computer.

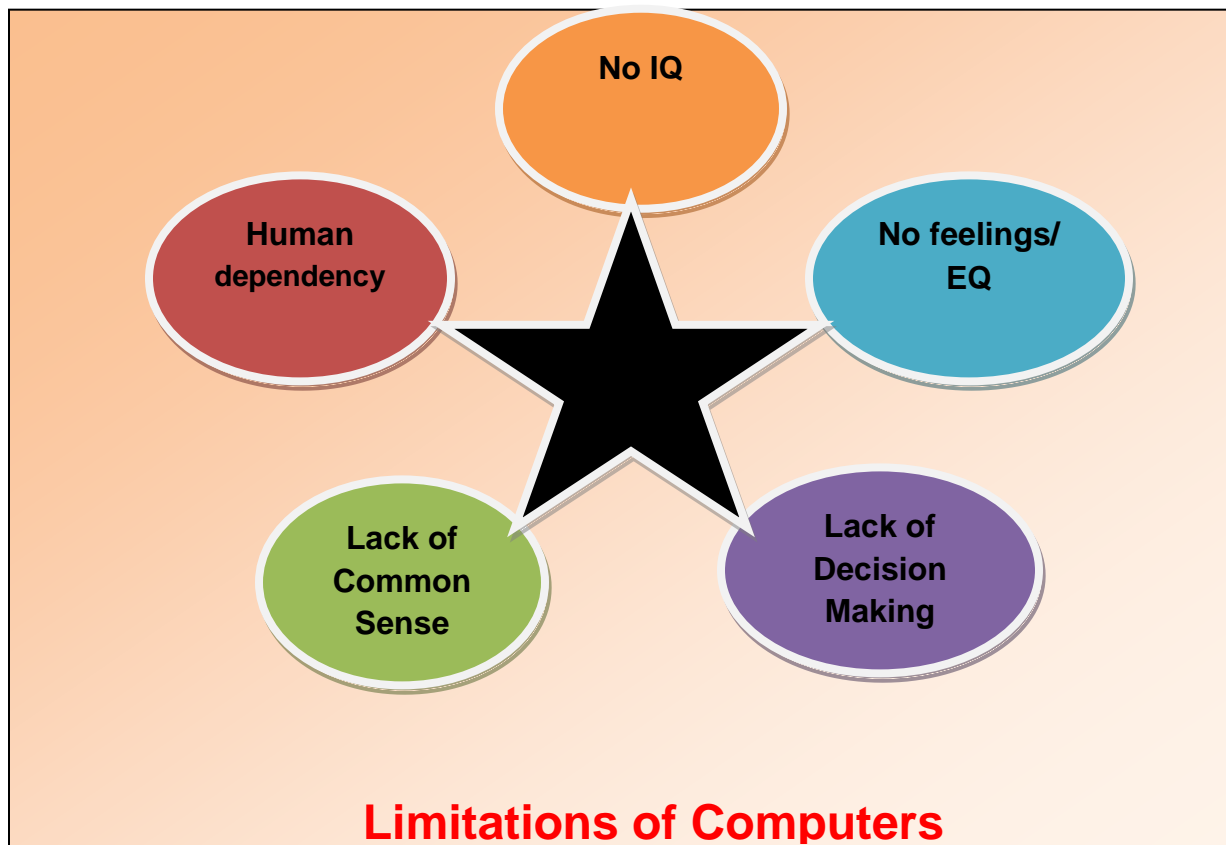

3. Lack of Decision Making

A computer cannot decide on its own. Each operation that the computer performs is fed with an algorithm to perform different processes for each situation. However, if it faces a problem that is not fed into the system, the computer is not ready for it. For making a decision humans have knowledge, wisdom, intelligence, the power to decide, etc. Computers have none of these.

4. Lack of Common Sense

A computer might be an automated machine still, it requires human assistance. It works only when it is provided with some input. For example in MS Word, Computer points to spelling and grammatical errors by underlining them with red ink. But it cannot correct it by itself.

5. Human dependency

A computer is a machine and is fully automated once switched on. But it cannot work to switch itself on. The computer also does not know when to start and when to stop unless it is fed with such a program. Some human assistance is always required in most situations. It cannot work completely on its own without human intervention.

EXERCISE

Q1. Answer the following questions.

1. A computer cannot decide on its own. Why?
2. Differentiate between hardware and software.
3. Explain any three characteristics of computer.
4. List some limitations of computer.
5. Write full form of the following-
 - a) CPU = _____
 - b) IQ= _____
 - c) RAM = _____
 - d) EQ = _____

Q2. Fill in the blanks.

Dump, human, zero, hardware, electronic

1. A computer is an _____ machine.
2. _____ are the parts of a computer that we can see and touch.
3. Computers have _____ IQ.
4. Computer is also called as _____ machine.
5. Computer cannot work completely on its own without _____ intervention.

Q3. Write "T" for true and 'F' for false for the given statements.

1. A computer does not have feelings. _____
2. Computer points to spelling and grammatical errors by underlining them with blue ink. _____
3. Computers have wisdom. _____
4. MS word is a hardware. _____
5. Computer takes inputs from users. _____

Q4. Complete the table with the help of the words given in the box.

MS paint, Speaker, CD, mouse, pen drive, keyboard, MS word, printer, Mac OS, floppy disk, android, DVD

Hardware	Software	Storage Device

CHAPTER – 2

Input and output Deices

Learning Objectives

- Students will be able to :
- Explain input devices
- Identify output devices
- Explain types and functions of Keyboard
- List types of Printers



Hello Friends.
Now let's learn about the different
Input Output devices

As you know that a computer is a machine. It can perform many tasks at the same time.



Let us take an example of a motorcycle. It has different parts like seat, tyres, engine, headlight etc. All these parts put together help the motorcycle to move.

The four main parts of a computer which are essential for a working system

1. System unit
2. Monitor
- 3 Keyboard
- 4 Mouse



There are many devices attached to a computer like Printer, Speaker, and Scanner etc.

Broadly, computer parts are divided into the following three categories:

- ❖ Input devices
- ❖ Output devices
- ❖ Processing devices

Let's learn about these devices in detail

Input devices

The devices through which we enter data and instructions into the computer are called Input Devices. Input devices are hardware components that allow a user to interact with a computer. They come in many forms, and the type of input device used depends on the type of task being performed

The three important input devices are: Keyboard, Mouse, Joystick.

Keyboard

Keyboards are one of the most common types of input devices, allowing users to enter data into computers quickly and accurately. It is a typing device.



Mouse

The mouse is the most used pointing device. It has two buttons and a scroll wheel in the center. It helps us to draw pictures. Using a mouse, we can point, select and drag any item on the monitor. While clicking and dragging, the mouse moves a little cursor across the screen



Joystick

A joystick is an input device that is commonly used to play games. It includes a base and a stick that can move to the left or right direction, also, it can be rotated in different directions.



Output devices

The devices which are used to show the results of input are called the output devices. Three commonly used output devices are Monitor, Printer, and Speaker.

Monitor

All that we type using the keyboard is displayed on Monitor. A monitor is an output device that is also known as a **video display unit (VDU)**. It is used to display images, text, video, and graphics although it is almost like a TV.



Printer

Printers are output devices that allow you to print results on paper. By using the printer we can get colored or black print outs.

Speakers

Speakers are output devices used with computer systems that enable us to listen to a sound as an outcome. The sound we record from a microphone can be heard from the speakers.



Types and Functions of a Keyboard:

Types of Keyboards

Keyboards are classified based on their mode of usage

1. QWERTY keyboard

Designed in the pattern of old-fashioned typewriters, QWERTY is the most common keyboard layout. The name comes from the order of the first six keys on the top left letter row of the keyboard (Q W E R T Y). The QWERTY keyboard layout is comfortable, familiar and time-tested, ideal for everyday typing needs.

2. Wired Keyboard

A wired keyboard means there is a wire connecting your keyboard to your computer. At the end of the wire is a USB plug that goes into a USB port on your computer. Wired keyboards are extremely reliable.

3. Wireless Keyboard

Wireless keyboard can be used if you connect your computer to either a screen or television so you can control it from the comfort of your bed or

sofa. They are relatively inexpensive and very easily available. Wireless devices communicate using radio waves.

4. Membrane Keyboard

Most QWERTY computer keyboards use a single rubber-like membrane underneath the keys that makes contact with a circuit board when the key is fully depressed.

5. Mechanical Keyboard

Mechanical keyboards are made with high-quality plastic key switches underneath each of the keycaps.

These keyboard switches are comprised of:

Keycap: the top cap with the letter/number.

Stem: the part underneath the keycap that moves down when pressed.

Functions of Keyboard:

The keys on your keyboard can be divided into several groups based on function:

- Typing (Alphanumeric) keys. These keys include the same letter, number, punctuation, and symbol keys found on a traditional typewriter.
- Control keys. These keys are used alone or in combination with other keys to perform certain actions. The most frequently used control keys are Ctrl, Alt, the Windows logo key , and Esc.
- Function keys. The function keys are used to perform specific tasks. They are labeled as F1, F2, F3, and so on, up to F12. The functionality of these keys differs from program to program.
- Navigation keys. These keys are used for moving around in documents or webpages and editing text. They include the arrow keys, Home, End, Page Up, Page Down, Delete, and Insert.
- Numeric keypad. The numeric keypad is handy for entering numbers quickly. The keys are grouped together in a block like a conventional calculator or adding machine.

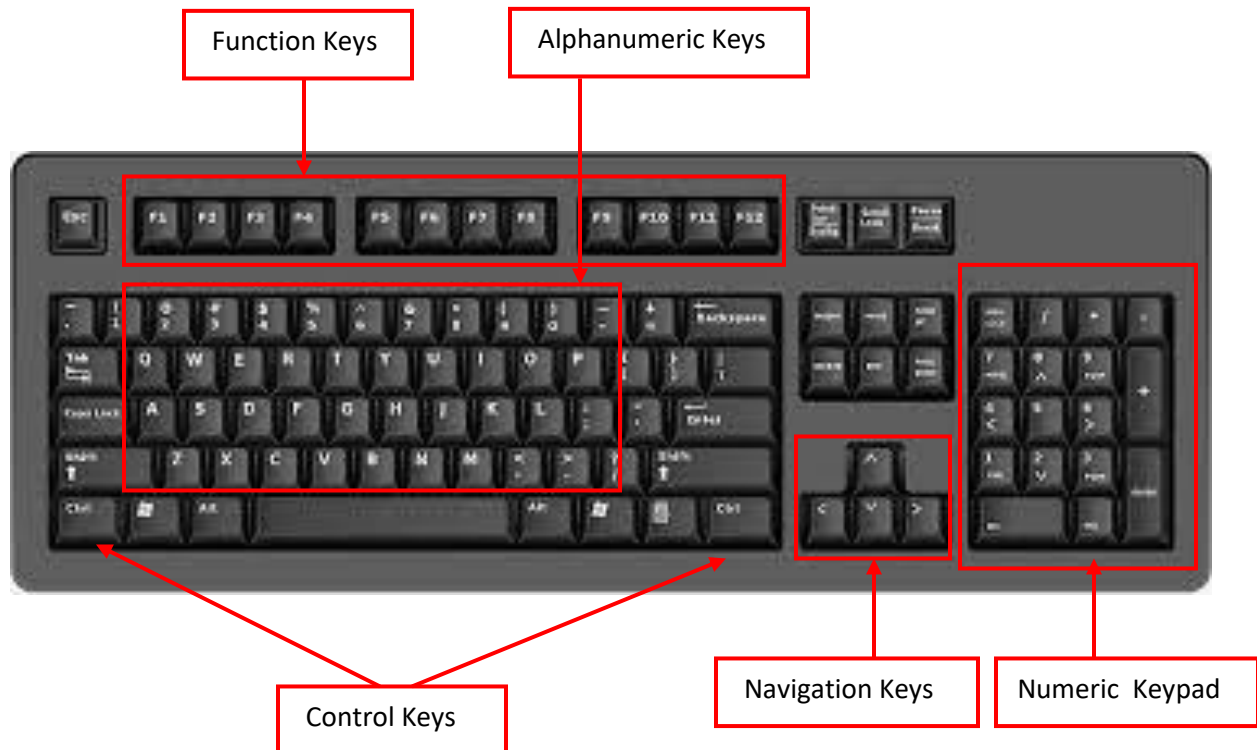

Other Functions of Keyboard

There are various other functions of keyboard, which are given below.

- Print Screen
- Scroll Lock
- Pause
- Brightness Up & Down
- Volume Up & Down

Types of Printers

Printers are output devices that allow you to print results on paper. How a printer prints or create graphics or text output on a paper decides its category. Based on the printing technology, printers are divided into two categories.

Impact Printer

Featuring the first category is an impact printer. It consists of one or more than one printing head, just like typewriters. In an impact printer, texts and graphics are produced on paper with the help of an ink ribbon hitting mechanism on paper.

Examples of this type of printer are Dot-matrix printers, daisy-wheel printers, and line printers.



Non-Impact Printer

Non-impact printers work differently than impact printers. It produces texts and graphics on paper without an ink ribbon hitting mechanism on paper. Examples of this type of printer are inkjet printer and laser printer.



Let's understand the fundamental difference between these printers in brief.

Impact Printer	Non-Impact Printer
Texts and graphics are printed on paper by striking	The non-impact printer prints text and graphics on paper without striking.
Impact printer uses electro-mechanical devices for printing.	The non-impact printer does not use it for printing.
It makes a lot of noise.	They are silent and make less noise as compared to impact printers.

EXERCISE

Q1. Fill in the blanks.

Radio, Speakers, input, pointing, keyboard

- 1) The devices through which we enter data and instruction into the computer are called _____ devices.
- 2) _____ is a typing device.
- 3) Wireless devices communicate using _____ waves.
- 4) Mouse is a _____ device.
- 5) _____ are output devices.

Q2. Answer the following questions.

- 1) What do you understand by input and output devices?
- 2) Write any three functions of keyboard.
- 3) Differentiate between impact printer and non-impact printer.
- 4) Write any three uses of mouse.
- 5) What are the main parts of a computer which are essential for its working?

Q3. Match the following.

F1, F2, F3

alphanumeric keys

A, B, C, D

control keys



Function keys

1, 2, 3, 4

Navigation keys

Ctrl

Numeric keys

Q4. Write "T" for true and 'F' for false for the given statements.

- 1) QWERTY is the most common keyboard layout. _____

2) Monitor is also known as Video Display Unit.

3) Joystick is used to display images.

4) Laser printer is a type of impact printer.

Q5. In the picture given below, colour the:



1. Control keys in orange
2. Navigation keys in yellow
3. Numeric keys in green
4. Function keys in red
5. Alphanumeric keys in blue

CHAPTER – 3

Introduction to Software

Learning Objectives

Students will be able to :

- define software
- list types of software
- explain System software , Application software and Utility software
- define Operating System



Hello Friends.

In this chapter, we are going to discuss about software

Software

Introduction

Computer system typically consists of Hardware, Software and users. Without even one of these, computer cannot fulfill any task. Therefore all three components are essential for a working machine. It is because of software or different applications, there are many uses of computer.

In the current world, modern software have surrounded us to make our lives better. Therefore, knowingly or unknowingly, we use different software to lead our day-to-day activities efficiently and more reliably. Furthermore, with time, people are becoming more tech-savvy. Software has such a powerful impact on our lives, but many of you might be thinking, "**what does software means**" or "**what are its various types that exist today?**".

It can be divided into three basic types: System Software, Application Software and Utility Software.

Let's quickly discover the definition and types of software

What is Software?

"Software is a set of programs (sequence of instructions) that allows the users to perform a well-defined function or some specified task."

Software is responsible for directing all computer-related devices and instructing them regarding what and how the task is to be performed. However, the software is made up of binary language (composed of ones and zeros), and for a programmer writing the binary code would be a slow and tedious task. Therefore, software programmers write the software program in various human-readable languages such as Java, Python, C#, etc.

Types of Software

Software's are broadly classified into two types, i.e., **System Software and Application Software**.

1. System Software

System software is a computer program that helps the user to run computer hardware or software and manages the interaction between them. Essentially, it is a software that constantly runs in the computer background, maintaining the computer hardware and computer's basic functionalities, including the operating system, utility software, and interface. In simple terms, you can say that the system software acts as a middle man that checks and facilitates the operations flowing between the user and the computer hardware.

System software is an essential part of your computer system. **They are the first thing that gets loaded in the system's memory whenever you turn on your computer. System software is also known as "low-level software"**

System software includes operating systems, device drivers, Firmware, libraries, compilers and other low-level programs that are essential for running the machine itself.

2. Application Software

Application software consists of programs designed to solve user problems. It provides users with tools necessary for completing specific tasks such as drawing using MS Paint, writing documents in word processor or creating spreadsheets in an Excel program. These programs generally come preinstalled on computers but users can also install new ones. They help people perform various activities ranging from simple ones like playing games to complex activities like data analysis and image manipulation.

3. Utility software

Utility software is designed to maintain system performance including optimizing disk space usage, cleaning up temporary files, scanning for viruses and malware etc. By using utility software regularly, users ensure their computers remain secure against

malicious threats while keeping them running at optimum speeds without any unnecessary clutter slowing down their systems over time.

Some of the common examples of utility software are as follows:

- Antivirus
- WinRAR
- Disk defragmenter
- WinZip

Operating System

The operating system is the most prominent example of system software that acts as an interface between the user and system hardware. **It is a group of software that handles the execution of programs and offers general services for the application that runs over the computer.**

There are several types of operating systems available for different kinds of computers ranging from traditional desktop machines to modern mobile phones. Popular examples include Windows for PCs and laptops, MacOS for Apple products like Mac Books or iMacs, Linux for server systems in addition to Android & iOS which run most smartphones today

Some of the commonly used examples of operating systems are given below.

- Microsoft Windows
- Apple's iOS
- Apple's MacOS
- Android
- Linux
- Ubuntu
- Unix

EXCERCISE

Q1. Fill in the blanks.

WinZip, system, software, zeros, users

- 1) _____ helps us to work efficiently and more reliably.
- 2) _____ is a utility software.
- 3) Computer system consists of hardware, software and _____.
- 4) _____ Software is also known as low-level software.
- 5) Binary language is composed of ones and _____.

Q2. Answer the following questions.

- 1) What are different types of software?
- 2) What is software?
- 3) Differentiate between system software and application software.
- 4) What do you mean by utility software?
- 5) Give some examples of Operating system.

Q3. Write 'T' for true and 'F' for false.

- 1) MacOS is used in apple products. _____
- 2) Application software helps in cleaning up temporary files. _____
- 3) Spreadsheets can be created in an Excel program. _____
- 4) System software runs constantly in computer background. _____
- 5) Python is not a human-readable language. _____

CHAPTER – 4

Memory and its types

Learning Objectives

Students will be able to :

- define Memory
- list types of memory
- differentiate between RAM & ROM
- list units of memory



Hello Friends.

In this chapter, we are going to discuss about Memory and its types.

Introduction

Till class II, you must have learnt about various concepts in English, Hindi, Mathematics, Computer etc. You must be able to read and write alphabets, numbers etc. All these concepts are stored in our brain as a memory. A memory is the ability of a person to remember things. Human brain is super intelligent and amazing organ of our body. It helps us do all the calculations, make decisions, control all other organs of the body, store and retrieve information. The human brain can store the information in the brain cells in the different parts of our brain. We can also retrieve this information depending upon how that information is stored in our brain.



In the same way, we can say that a computer also has memory. A computer memory is used to store data and instructions that help in the execution of various tasks and functions.

Memory

Computer memory is the physical storage device that allows a computer to store and access data, including programs and instructions. Memory is typically divided into two types: primary memory and secondary memory.

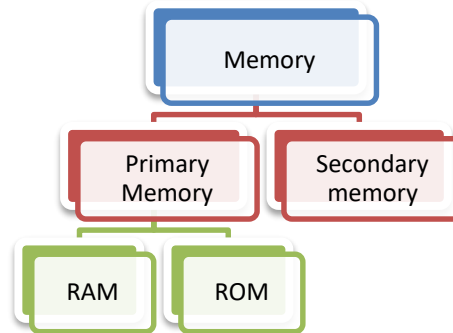

Primary Memory:

Primary memory is known as the main memory of the computer. Primary memory is located on the mother board. Primary memory allows computers to access data quickly and efficiently, helping them operate faster. There are two types of Primary Memory : RAM and ROM

Random Access Memory (RAM) :

RAM is also known as volatile or temporary memory. It stores data temporarily while the processor is executing instructions. This type of storage can be accessed randomly by the processor without having to read through other stored items first. The data will be erased once the computer is turned off.



Read Only Memory (ROM) :

The data saved on ROM is permanent. Therefore ROM (Read-Only Memory) is a non- volatile memory. ROM holds certain instructions used during starting of computer. This prevents any changes from being made once written into ROM. In ROM the data is not lost when the computer is turned off.



Secondary Memory:

Secondary memory is also known as secondary storage. The secondary memory is accessed indirectly via input/output operations. This memory is also called permanent, external, stable or persistent memory. It is characterized by its slowness and cheapness, relative to the RAM, and by its permanent appearance. The Secondary

memory store data that can be easily retrieved only by the main memory and used by the processor. It is slower than RAM but larger storage capacities than primary memory.

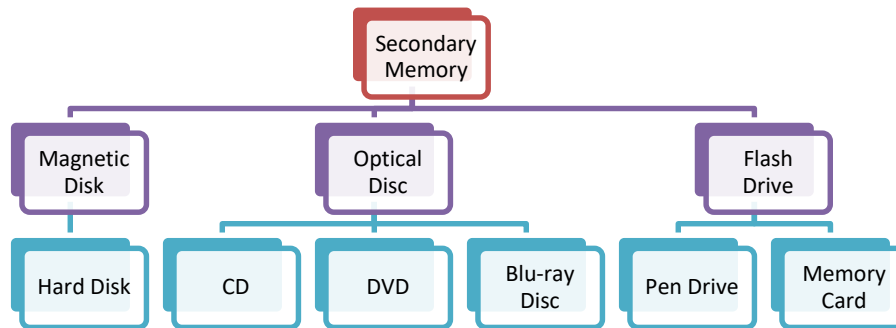

We shall study more about them in class IV .

Units of memory

When talking about computer memory, it's important to understand how it's measured in terms of units like bytes, kilobytes, megabytes, gigabytes, terabytes, petabytes etc. A byte is a unit of digital information consisting of 8 bits (binary digits). Kilobyte (KB) is equal to 1024 bytes or 1 thousand bytes; megabyte (MB) equals 1 million bytes; gigabyte (GB) equals 1 billion bytes; terabyte (TB) equals 1 trillion bytes; petabyte(PB), exabyte(EB), zettabyte(ZB), yottabyte(YB), Bronto Byte these are all much larger than their preceding values with each one being 1000 times bigger than the last one mentioned before it.

Computer Memory - Units of measurements	
1 Bit (Binary Digit)	Binary 0 or 1
4 bits	1 Nibble
8 bits	1 Byte
1024 Bytes	1 Kilo Byte (KB)
1024 Kilo Byte	1 Mega Byte (MB)
1024 Mega Byte	1 Giga Byte (GB)
1024 Giga Byte	1 Tera Byte (TB)
1024 Tera Byte	1 Peta Byte (PB)
1024 Peta Byte	1 Exa Byte (EB)
1024 Exa Byte	1 Zetta Byte (ZB)
1024 Zetta Byte	1 Yotta Byte (YB)
1024 Yotta Byte	1 Bronto Byte
1024 Bronto Byte	1 Geop Byte

EXERCISE

Q1. Write 'T' for true and 'F' for false.

- 1) The human brain can store the information in the brain cells. _____
- 2) In RAM the data is not lost when the computer is turned off. _____
- 3) Secondary memory is known as the main memory of the computer. _____
- 4) A byte is a unit of digital information. _____

Q2. Fill in the blanks.

Permanent, primary, 1024, mother board, memory

- 1) _____ Memory is also known as main memory of the computer.
- 2) _____ is the ability to remember things.
- 3) Secondary memory is also known as _____ memory.
- 4) Kilobyte (KB) is equal to _____ bytes.
- 5) Primary memory is located on the _____.

Q3. Answer the following questions.

- 1) Write any three differences between RAM and ROM.
- 2) Computer also has memory. Explain.
- 3) Write any three examples of Secondary memory.
- 4) Differentiate between primary and secondary memory.

Q4. Complete the table.

Computer memory units	
1 Bit (B inary D igit)	Binary 0 or 1
4 bits	
	1 Byte
	1 Kilobyte (KB)
1024 Kilobyte	
	1 Gigabyte (GB)
1024 Gigabyte	
	1 Petabyte (PB)
1024 Petabyte	
	1 Zettabyte (ZB)
1024 Zettabyte	

CHAPTER – 5

Multimedia and Internet

Learning Objectives

Students will be able to :

- define Multimedia
- list components used in multimedia
- learn how to play music and video
- understand about Internet and websites



Hello Friends.

In this chapter, we are going to discuss about Multimedia and Internet.

Introduction

Multimedia is a term used to refer to content that combines **more than one form of media**, such as text, audio, video ,imagesand animations. It has become increasingly popular in recent years. Multimedia can be used for various purposes including entertainment, education and advertising. Common components include audio (such as sound effects or music), video (including live footage or animation), images (from photographs or illustrations) and animations (which may range from simple transitions between slideshows up to complex 3D models). Each type of media requires different techniques in terms of production and playback.

Text

Text is the basic components of multimedia and most common ways of communicating information to other person. Even though multimedia includes images, video, audio and graphics, Text is the basic components used in multimedia. There are two types of text : Static Text and Hypertext.

Static Text

Static text, the text or the words will remain static as a heading or in a line, or in a paragraph.

Hypertext

A hypertext is a system which consists of text and the links between the text.

Audio

Audio is a key component of multimedia content, used to enhance the overall experience. There are two main types of audio: recorded sound and synthesized sound. Recorded sound includes anything that has been recorded onto an audio medium such as CDs, while synthesized sound is created using digital instruments and sequencers. Both can be used in multimedia projects.

Video

Video is a powerful tool in multimedia projects, often used to show live action or animation. Video is defined as the display of recorded event, scene etc. The powerful way to convey information in multimedia applications are embedding of video. The video can be categorized in two types as Analog video and Digital video.

Images

Images act as an vital component in multimedia. These images are generated by the computer in two ways, as bitmap or raster images and as vector images.

Bitmap or Raster Images

The common and comprehensive form of storing images in a computer is raster or bitmap image. Bitmap is a simple matrix of the tiny dots called pixel that forms a raster or bitmap image.

Vector Images

Drawing elements or objects such as lines, rectangles, circles and so on to create an images are based on Vector images. The advantage of vector image is relatively small amount of data is required to represent the image and thereby only less memory is needed to store. Various Compression formats used for this purpose are GIF, TIFF and JPEG.

Animations

Animation is the process displaying still images so quickly so that they give the impression of continuous movement. In animation the screen object is a vector image in

animation. There are many different types of animations that can be used depending on the context and desired effect; these range from simple 2D vector graphics to complex 3D models. The two basic types of animations are Path animation and Frame animation.

Play Music and Video

Playing a sound, music, or other audio file in Windows requires that you use a media player program that can play the audio file.

To open Windows Media Player and play the file, follow the steps below.

1. Click the Start button.
2. Go to All Apps, Windows Accessories
3. Click Windows Media Player.

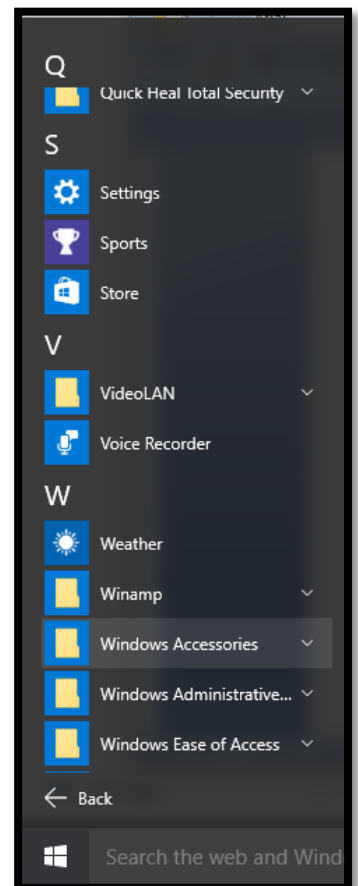
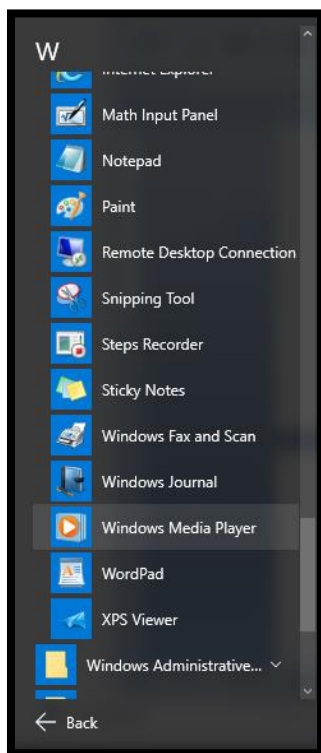

Click Music → Album → Select the audio file to play the music

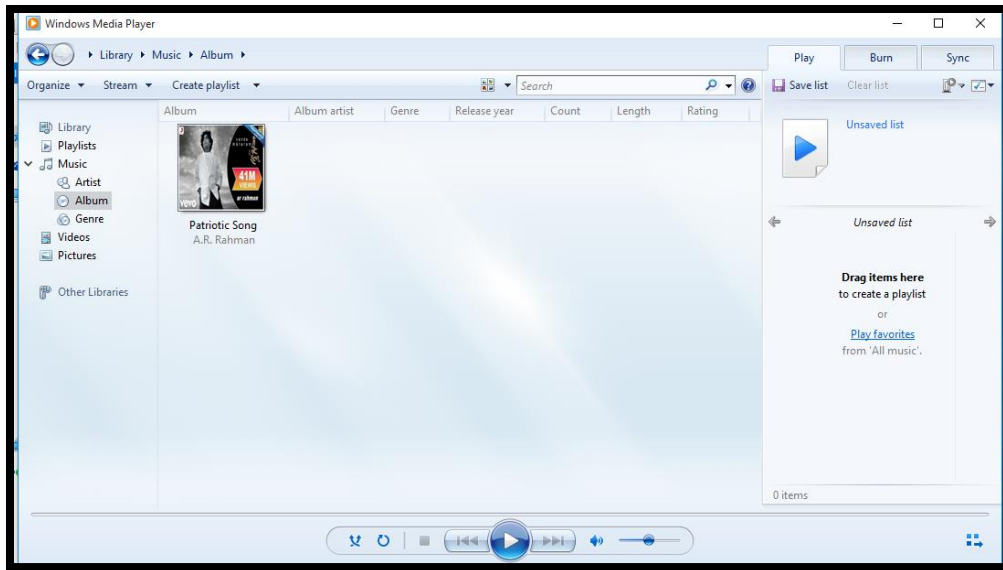

Similarly a video can be played using Windows Media player by selecting Videos from the library.

What is Internet ?

Internet is the foremost important tool and the prominent resource that is being used by almost every person across the globe. It connects millions of computers, web pages, websites, and servers. Using the internet we can send emails, photos, videos, messages to our loved ones. Or in other words, the internet is a widespread interconnected network of computers and electronics devices (that support internet). It creates a communication medium to share and get information online. If your device is connected to the Internet then only you will be able to access all the applications, websites, social media apps, and many more services. Internet nowadays is considered as the fastest medium for sending and receiving information.

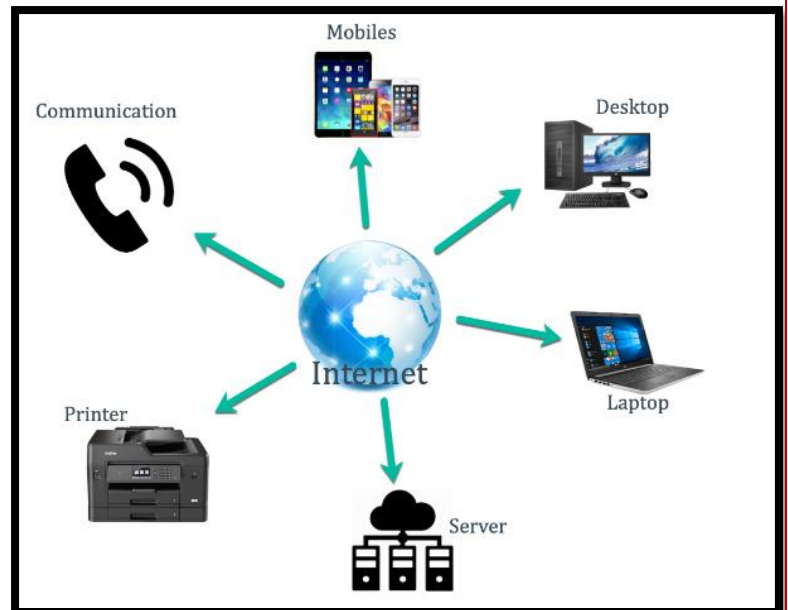

How does the Internet works?

The actual working of the internet takes place with the help of clients and servers. Here the client is a laptop that is directly connected to the internet and servers are the computers connected indirectly to the Internet and they are having all the websites stored in those large computers. These servers are connected to the internet with the help of ISP (Internet Service Providers) and will be identified with the IP address.

Websites

A website is a collection of many web pages, and web pages are digital files that are written using HTML (Hyper Text Markup Language). To make your website available to every person in the world, it must be stored or hosted on a computer connected to the Internet . Such computers are known as a Web Server.

The website's web pages are linked with hyperlinks and hypertext and share a common interface and design. The website might also contain some additional documents and files such as images, videos, or other digital information. Websites can be used as business tools, educational resources or personal platforms for individuals and organizations alike.

There are two types of Websites

- Static Website
- Dynamic Website

Static Website: In Static Websites, Web pages are provided by the server which prebuilt source code files are built using simple languages such as HTML, CSS, or JavaScript. There is no processing of content on the server (according to the user) in Static Websites.

Dynamic Website: In Dynamic Websites, Web pages are returned by the server which is processed during runtime means they are not prebuilt web pages, but they are built during runtime according to the user's demand.

EXERCISE

Q1. Write 'T' for true and 'F' for false.

- 5) Through audio we can show live action or animation. _____
- 6) ISP stands for Internet Service Products. _____
- 7) Synthesized sound is created using digital instruments and sequencers. _____
- 8) Through internet we cannot share any information. _____

Q2. Fill in the blanks.

Animation, hypertext, multimedia, vector, digital

- 6) _____ is a term used to refer more than one media.
- 7) A _____ is a system which consists of text and the links between the text.
- 8) In animation the screen object is a _____ image.
- 9) Web pages are _____ files that are written using HTML.
- 10) _____ is the process displaying still images quickly.

Q3. Answer the following questions.

- 5) Explain about any three multimedia from your daily life.
- 6) What is internet?
- 7) How images are generated by the computer?
- 8) How does internet works?
- 9) What is Web server? Name two types of websites.

CHAPTER – 6

MS Word

Learning Objectives

Students will be able to :

- Learn various Menus of MS Word
- explain different tabs
- apply formatting to text
- create bullets and numbers
- create table in MS Word



Hello Friends.

In this chapter, we are going to discuss about MS Word and its tools

Introduction

Microsoft Word is word processing software. It is developed by Microsoft and is part of Microsoft Office Suite. It enables you to create, edit and save professional documents like letters and reports.

Office Button :



The office button is an essential element of Microsoft Office Suite 2007. This button was introduced in Office 2007 with the new Ribbon feature. When we click on the Office button, it displays some useful options to open, save, print any document, or perform other common functions.

Office Button Menu Options

The following options or commands are displayed when we click on the Office button:

- **New:** This option allows us to create a new, blank file in the corresponding Office program, such as MS Word, MS Excel, PowerPoint, etc.
- **Open:** This option allows us to open an existing file from the local storage on our computer.
- **Save:** This option allows us to permanently save a temporary file to our computer after finishing the work.
- **Save As:** This option allows us to save a copy of the active file with the desired file name and file extension to a desired location on the computer storage.
- **Print:** This option allows us to take a hard copy of the desired document on paper through a printer.
- **Prepare:** This option allows us to prepare the active file for distribution. In particular, the prepare option helps us view and modify the document properties accordingly.
- **Send:** This option enables us to send or share the desired files directly through the opened Office program with others. In particular, we may share active documents by e-mail, upload them to OneDrive, or post to a specific blog.
- **Publish:** This option enables us to distribute the desired document to people. We can even create a specific blog article with the content inside the file.
- **Close:** This option helps us to close an active document in a corresponding Office program.

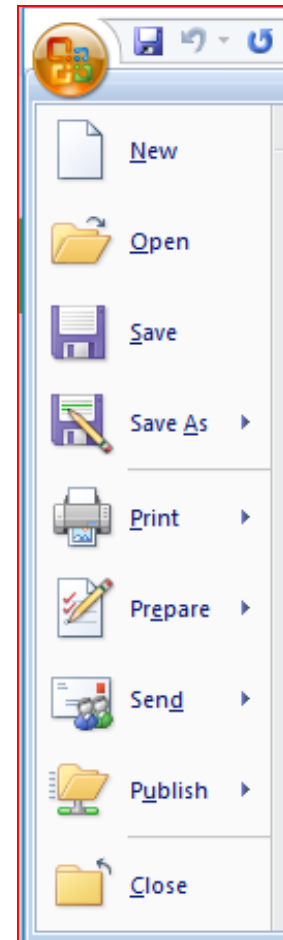

Quick Access Toolbar

Quick Access Toolbar lies next to the Microsoft Office Button. It is a customizable toolbar that comes with a set of independent commands. It gives you quick access to commonly used commands such as Save, Undo, Redo, etc.

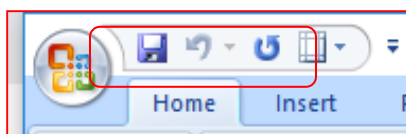

When you click the drop-down arrow next to toolbar it offers more commands. With a left click you can add any of these commands to Quick Access Toolbar. You can also remove the commands added to the tool bar. The following image is showing the menu of quick access toolbar.

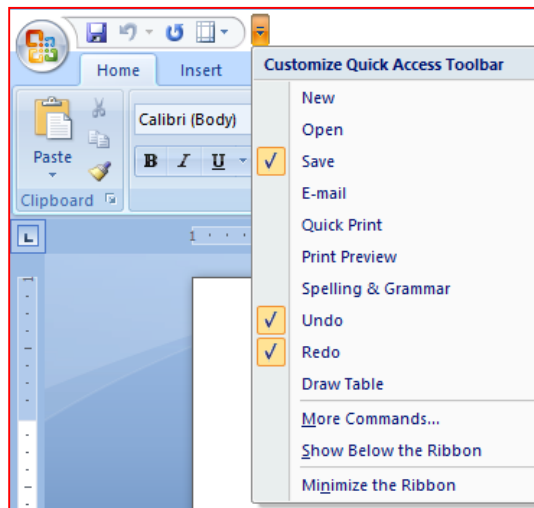

Title Bar

It lies next to the Quick Access Toolbar. It displays the title of the currently opened document. It is present on almost all windows displayed on your computer. So, if there are several windows across the screen, you can identify each window by looking at the title bar.

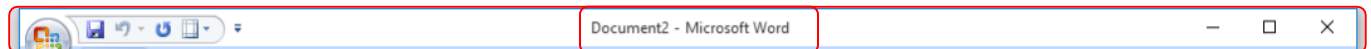

Ribbon and Tabs

It is located below the Quick Access Toolbar and the Title Bar. It comprises seven tabs; Home, Insert, Page layout, References, Mailings, Review and View. Each tab has specific groups of related commands. It gives you quick access to the commonly used commands that you need to complete a task.

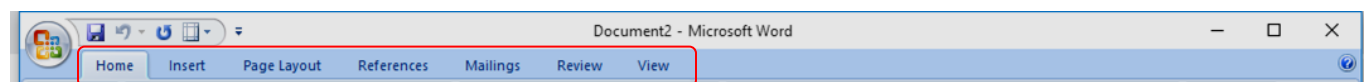

Home tab:

The Home tab is the default tab in Microsoft Word. It has five groups of related commands; Clipboard, Font, Paragraph, Styles and Editing. It helps you change document settings like font size, adding bullets, adjusting styles and many other common features. It also helps you to return to the home section of the document.

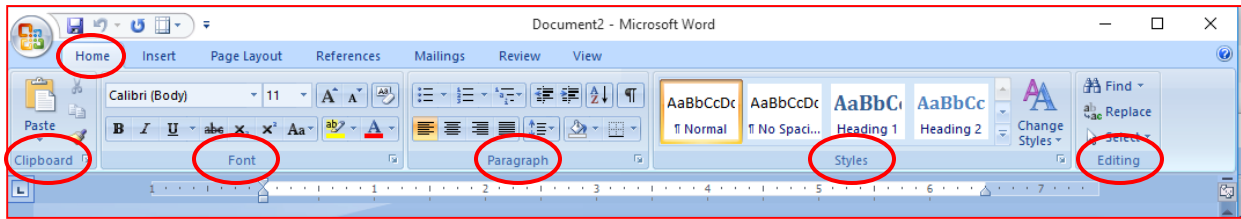

Insert tab:

Insert Tab is the second tab in the Ribbon. As the name suggests, it is used to insert or add extra features in your document. It is commonly used to add tables, pictures, clip art, shapes, page number, etc. The Insert tab has seven groups of related commands; Pages, Tables, Illustrations, Links, Header & Footer, Text and Symbols.

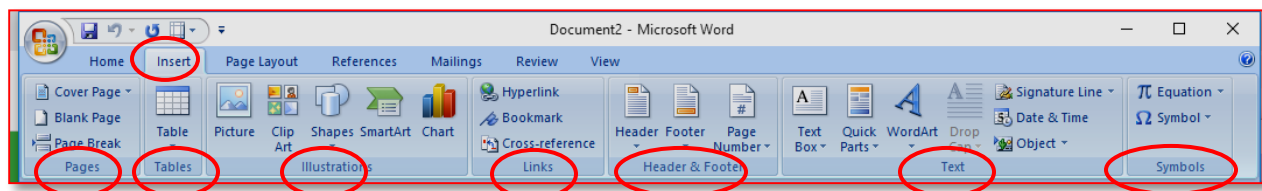

Page Layout tab:

It is the third tab in the Ribbon. This tab allows you to control the look and feel of your document, i.e. you can change the page size, margins, line spacing, indentation, documentation orientation, etc. The Page Layout tab has five groups of related commands; Themes, Page Setup, Page Background, Paragraph and Arrange.

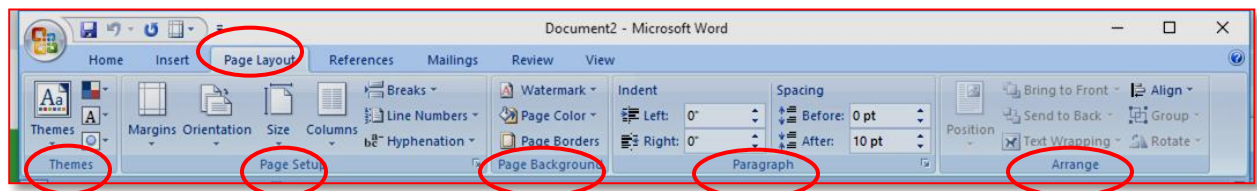

References tab:

It is the fourth tab in the Ribbon. It allows you to enter document sources, citations, bibliography commands, etc. It also offers commands to create a table of contents, an index, table of contents and table of authorities. The References tab has six groups of related commands; Table of Contents, Footnotes, Citations & Bibliography, Captions, Index and Table of Authorities.

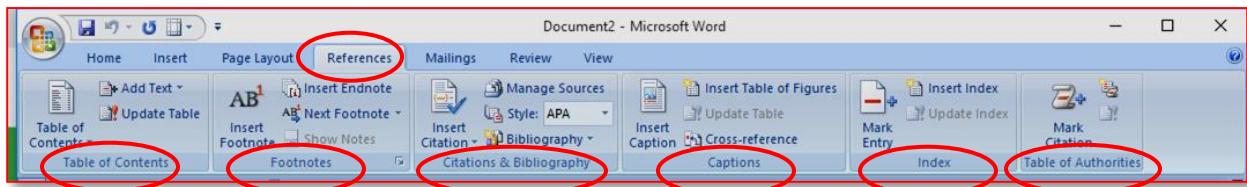

Mailings tab:

It is the fifth tab in the ribbon. It is the least-often used tab of all the tabs available in the Ribbon. It allows you merge emails, writing and inserting different fields, preview results and convert a file into a PDF format. The Mailings tab has five groups of related commands; Create, Start Mail Merge, Write & Insert Fields, Preview Results and Finish.

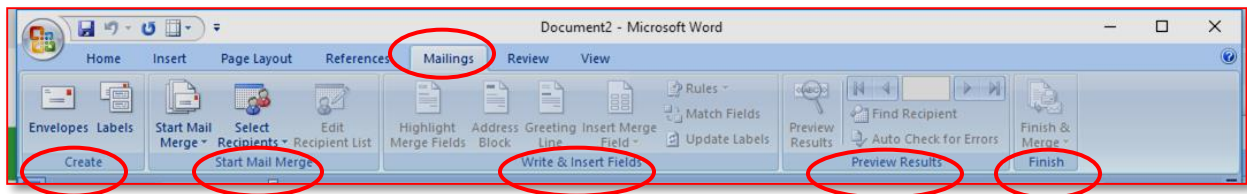

Review tab:

It is the sixth tab in the Ribbon. This tab offers you some important commands to modify your document. It helps you proofread your content, to add or remove comments, track changes, etc. The Review tab has six groups of related commands; Proofing, Comments, Tracking, Changes, Compare and Protect.

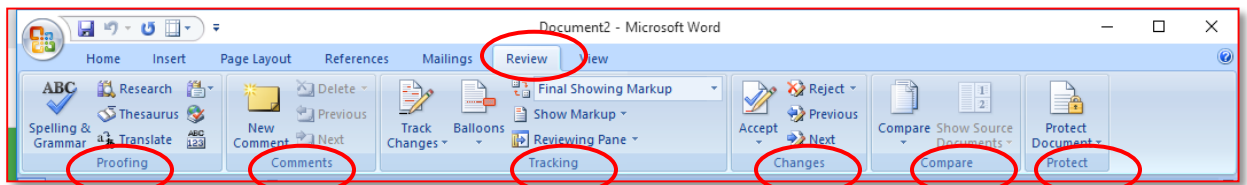

View tab:

The View tab is located next to the Review tab. This tab allows you to switch between Single Page and Two Page views. It also enables you to control various layout tools like boundaries, guides, rulers. Its primary purpose is to offers you different ways to view your document. The View tab has five groups of related commands; Document Views, Show/Hide, Zoom, Window and Macros.

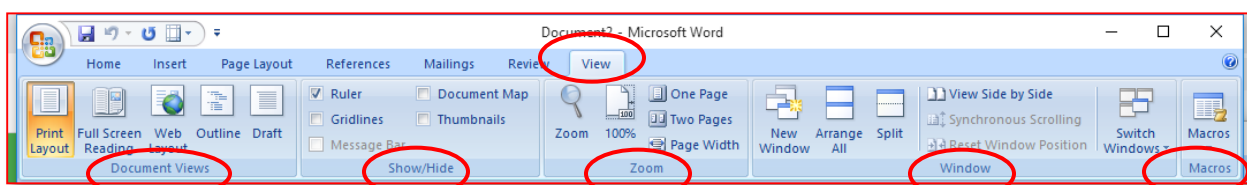

Ruler

The Ruler is located below the Ribbon around the edge of the document. It is used to change the format of the document, i.e. it helps you align the text, tables, graphics and other elements of your document. It uses inches or centimeters as the measurements unit and gives you an idea about the size of the document.

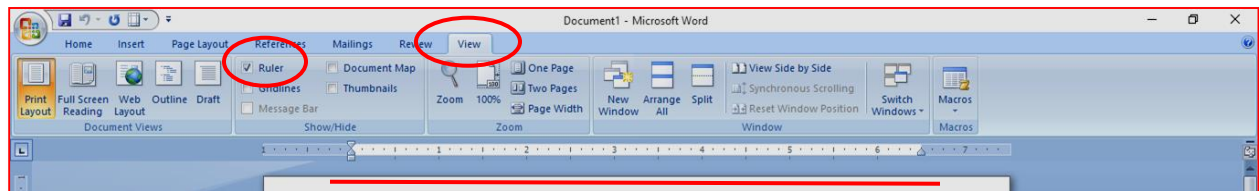

How to Insert Text in MS Word

The basic steps to insert text or to create a new document in Word are listed below;

- Go to the start menu and look for Microsoft Word icon
- Click the icon to open the Microsoft Word
- You will see a blinking cursor or insertion point in the text area below the ribbon
- Now, as you start typing, the words will appear on the screen in the text area
- To change the location of insertion point press spacebar, Enter or Tab keys

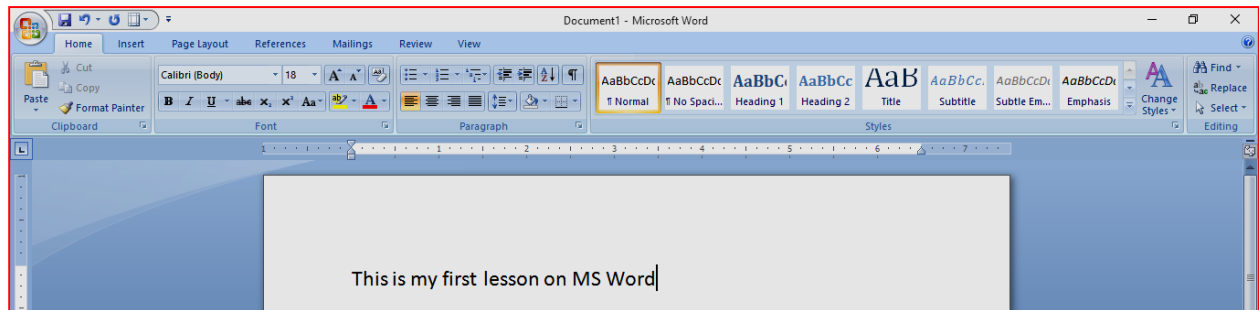

How to Select Text in MS Word

Place the cursor next to the text then left click the mouse and holding it down move it over the text then release it. The text will be selected.

Some shortcuts for selecting text are:

- To select a single word double click within the word
- To select the entire paragraph triple click within the paragraph
- To select entire document, in Home tab, in Editing group click Select then choose Select All option or press CTRL+A

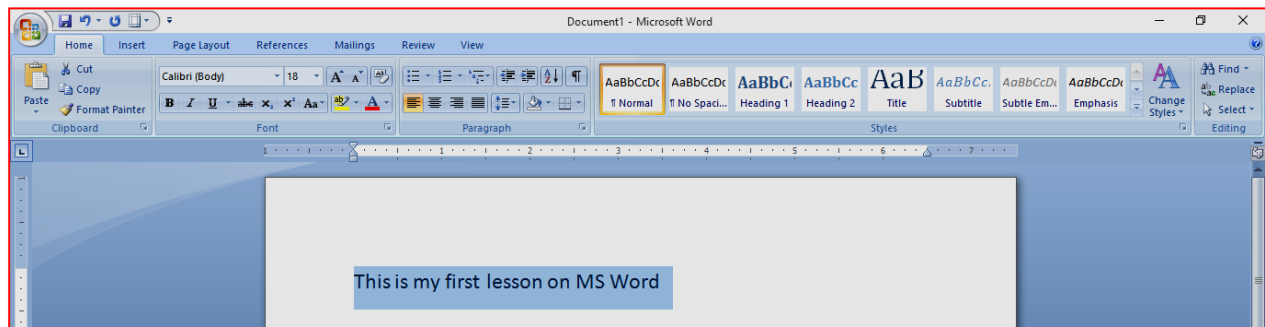

How to Delete Text in MS Word

You can easily delete the text in Word including characters, paragraphs or all of the content of your document. Word offers you different methods to delete the text; some of the commonly used methods are given below;

- Place the cursor next to the text then press Backspace key
- Place the cursor to the left of the text then press Delete key
- Select the text and press the Backspace or Delete key
- Select the text and type over it the new text.

How to Change Font Size in MS Word

You can easily change the font size of your text in the document. The basic steps to change the Font size are listed below;

- Select the text that you want to modify
- In Home tab locate the Font group
- In Font group click the drop-down arrow next to font size box
- Font size menu appears
- Select the desired font size with a left click

- Select the text and click the increase or decrease font size buttons

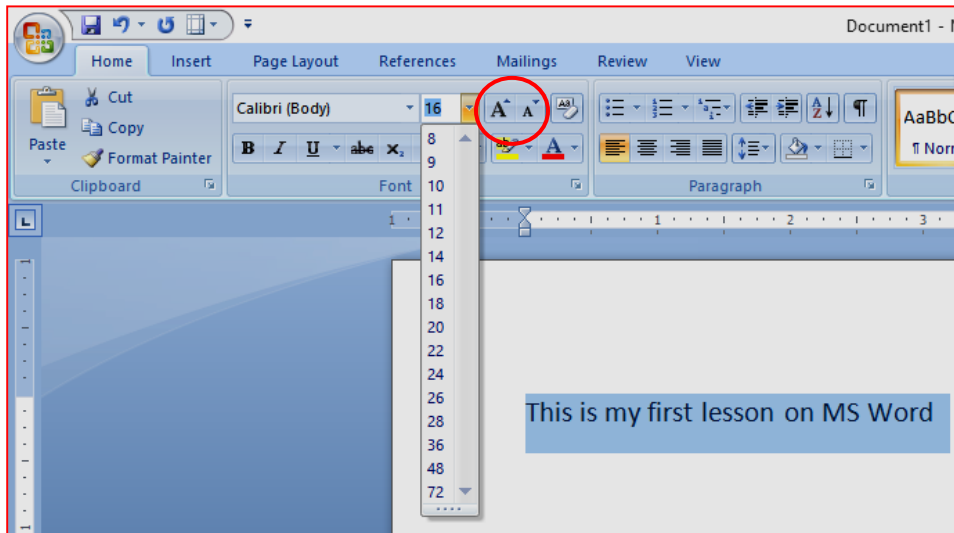

How to Change Font Style in MS Word

The basic steps to change the font of a text in a document are given below;

- Select the text you want to modify
- Select the Home tab and locate the Font group
- Click the drop-down arrow next to font style box
- Font style menu appears
- With a left click select the desired font style
- If you want to change the font to **bold** *italic* , click the 'B' or 'I' icons on the format bar.

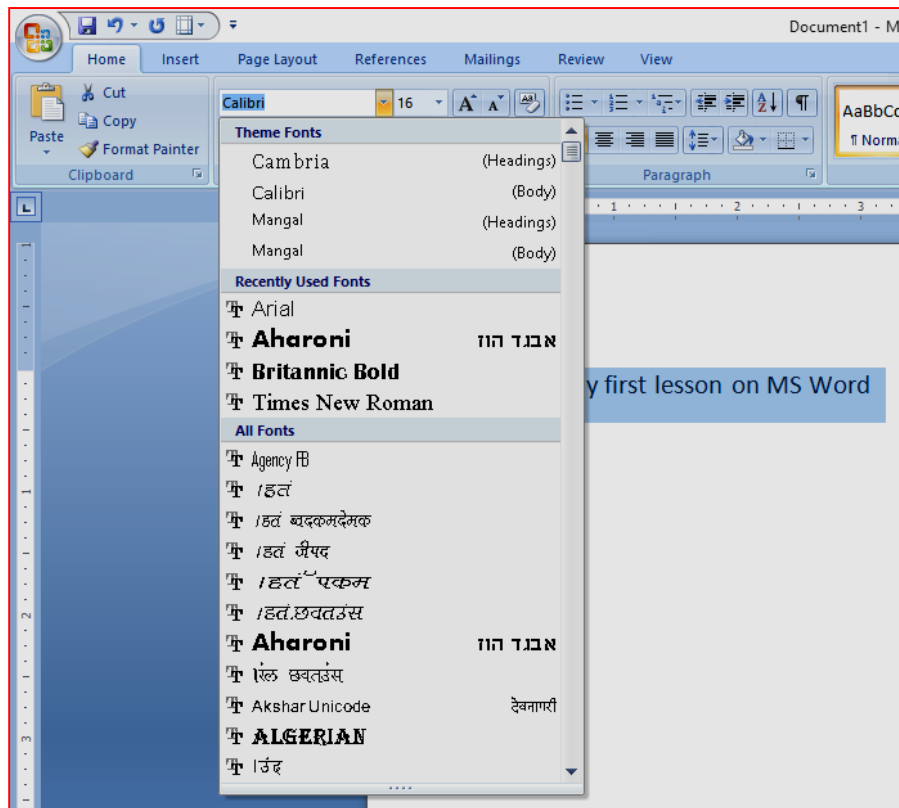

How to Change Text Alignment in MS Word

You can change the text alignment in your document to make it more presentable and readable. The basic steps to change the text alignment are given below;

- Select the content you want to modify
- In Home tab locate the Paragraph group
- It has four alignment options ;

Align Text Left: Aligns the text towards left margin

Center: Brings the text at centre

Align Text Right: Aligns the text towards right margin

Justify: Aligns the text to both left and right margins

- Select the desired alignment option with a left click

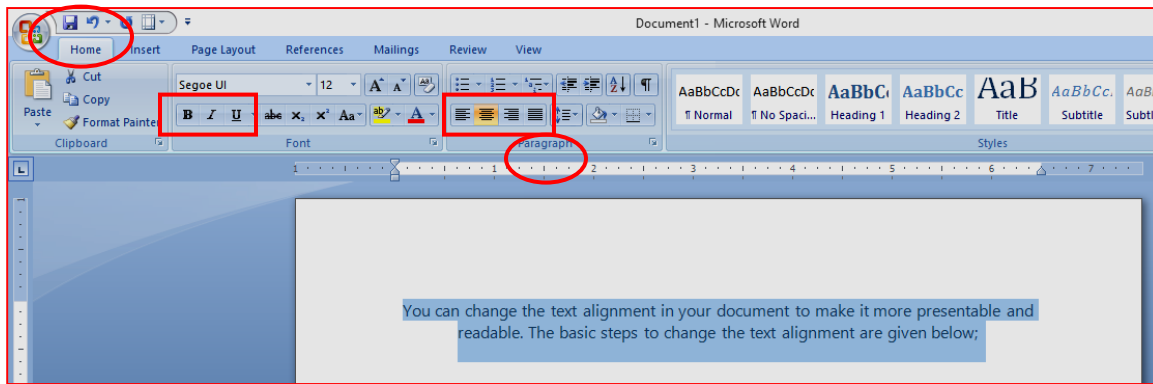

How to Create Bulleted and Numbered Lists

Bullets and numbers are used to make a list more presentable and readable. A bulleted list attracts more than a simple list. Word offers you various styles of bullets and numbers. The steps to create bulleted lists are given below;

- Select the text you want to convert to bulleted or numbered list
- Select the Home tab
- In Paragraph group click the Bullets or Numbering command
- It displays Bullets or Numbering menu
- With a left click select the desired Bullet or Numbering style
- To increase the list place the cursor at the end of list and press Enter key

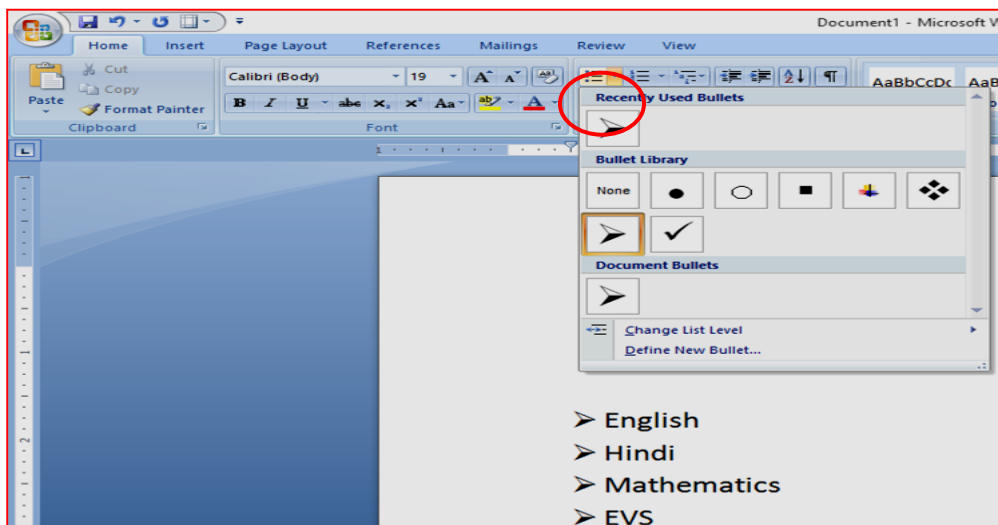

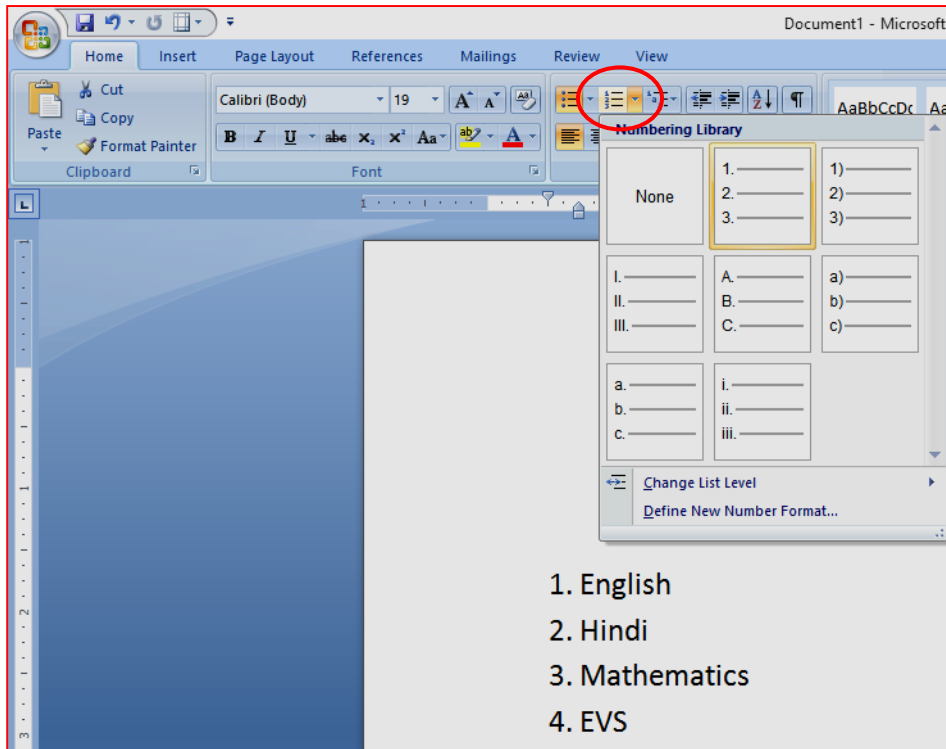

How to Increase or Decrease the Indent level of the paragraph

To increase or decrease the indent level

1. Select one or more paragraphs that you want to adjust.
2. Go to Home and then select the Paragraph dialog box launcher.
3. Choose the Indents and Spacing tab.

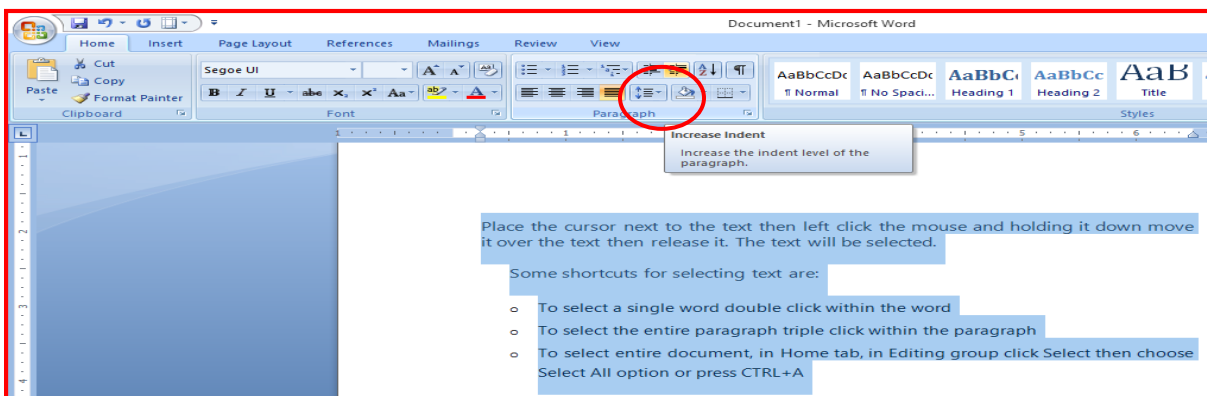

How to Create a Table in MS Word

Table is a versatile tool of MS Word. It allows you to organize your information, i.e. you can align text, present numerical data and create forms and calendar. The steps to insert table are given below;

- Place the cursor where you want to insert the table
- Select the Insert tab
- In Tables group click the Table command
- It displays different options to insert the table
- Select the desired option to insert the table

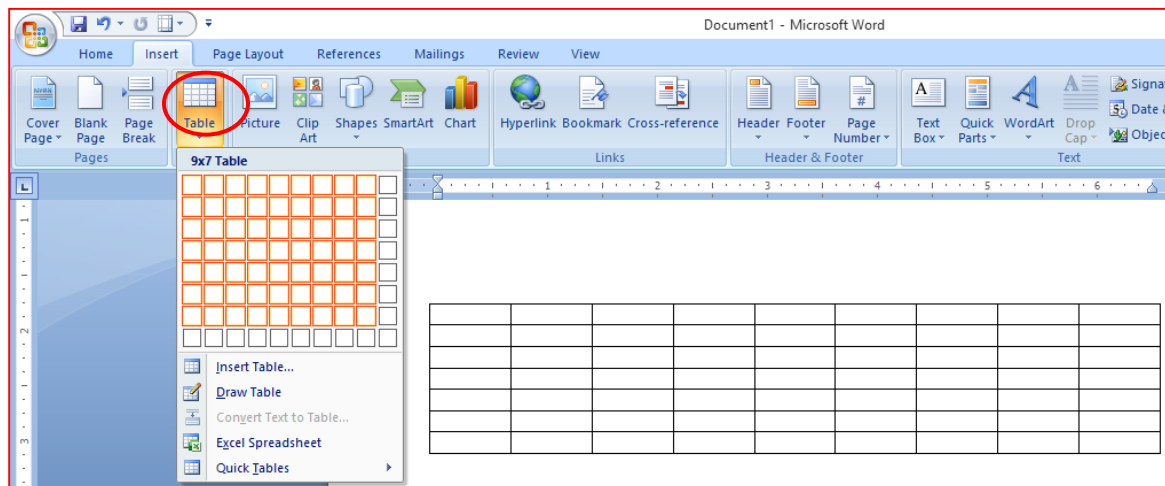

EXERCISE

1. Explain any five commands of Office button.
2. What does a title bar display ?
3. Explain Home Tab, Insert tab and Page Layout tab.
4. What is a ruler ?
5. What are different shortcuts for selecting text ?
6. What is default font size of any document ?
7. What do you mean by bullets and numbers ?
8. What is a table ? How to create a table in MS Word ?

CHAPTER – 7

MS Paint - Advanced

Learning Objectives

Students will be able to :

- Explain different tabs of MS Paint
- Use Text tool, Color Picker Tool, Eraser Tool , Pencil Tool
- Explain different views
- Use different shapes
- use color palette



Hello Friends.

In this chapter, we are going to discuss more about MS Paint and its tools

In class II, you must have learnt how to draw lines and shapes, how to fill the shapes with different colors. In this chapter you are going to use various tools like Font, color, eraser, pencil. Also we will discuss Home Tab and View Tab and their commands

Home tab:

The Home tab is the default tab in Microsoft Paint It has five groups of related commands; Clipboard, Image, Tools, Shapes and Colors.. It also helps you to return to the home section of the document.

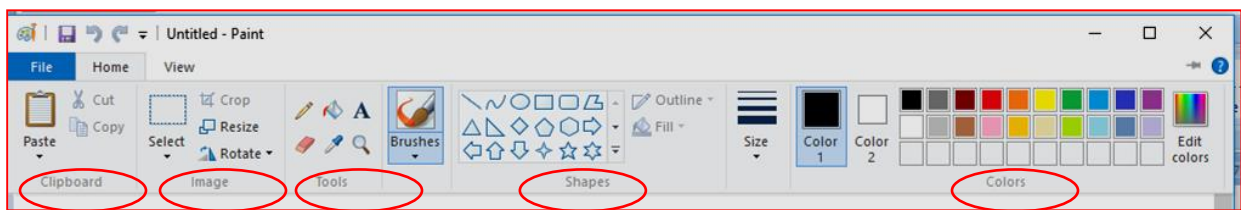

Tools Group

The Tools group contains six drawing tools

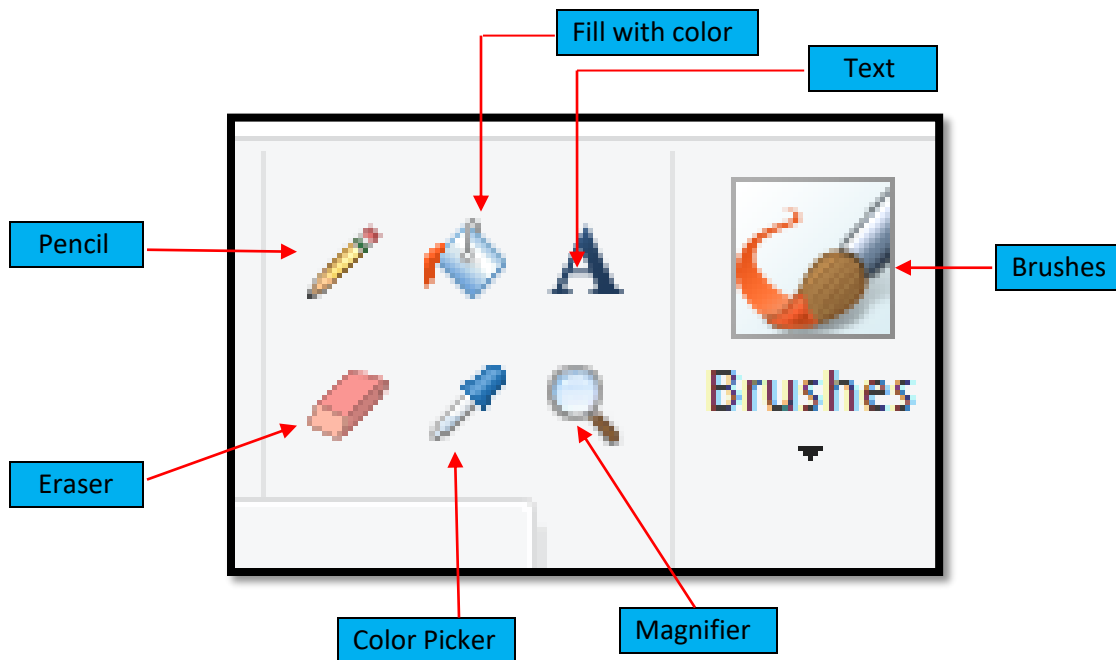

1. TEXT Tool

In order to type message in Paint, we can use the Text tool. To type a text, follow the given steps :

Step 1. Click on Home tab

Step 2. Select the Text tool from the Tools group

Step 3. Bring the pointer to the drawing area. Click where you want to add the text. A textbox will appear

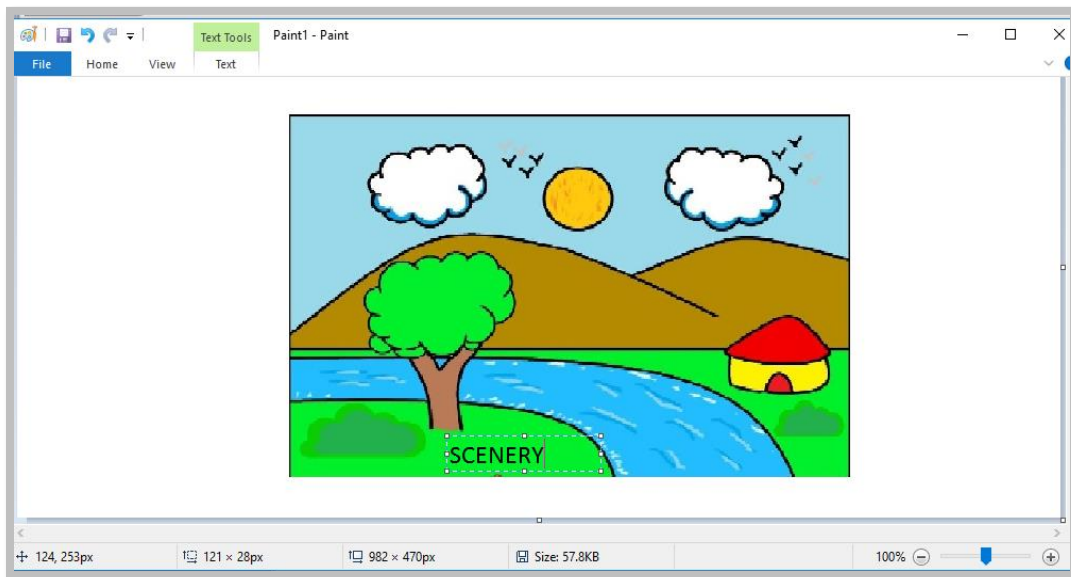
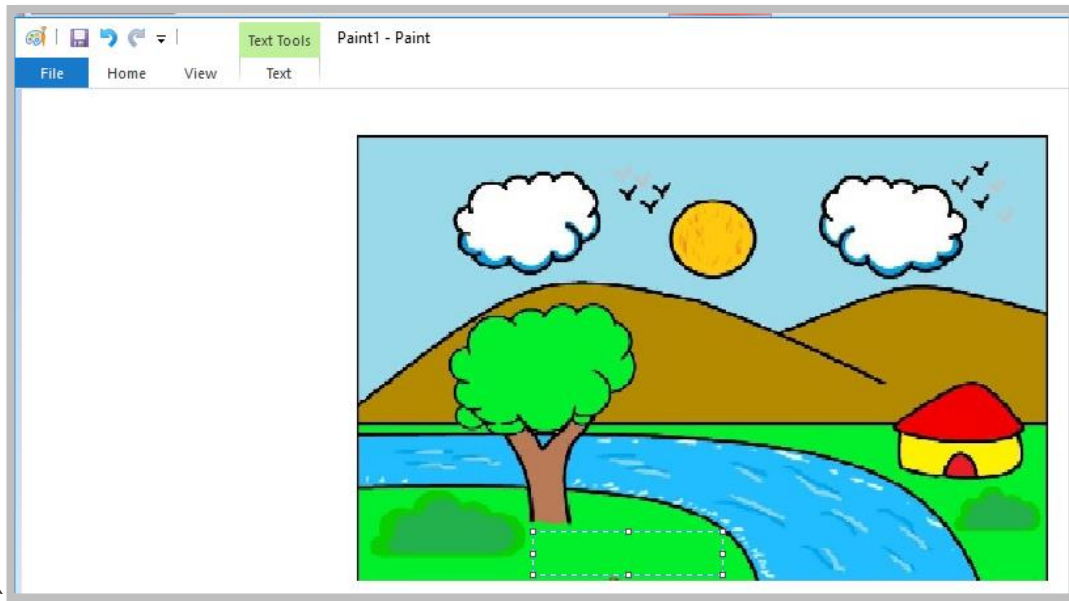

2. Color Picker Tool

This tool is used to pick an exact color from any image and that color can be used to fill color anywhere on the drawing area.

Follow these steps to use this tool

1. Draw any two shapes in the drawing area and fill different colors in them. For example a Red Circle and a Green Diamond
2. Select the color picker tool from the tools Group

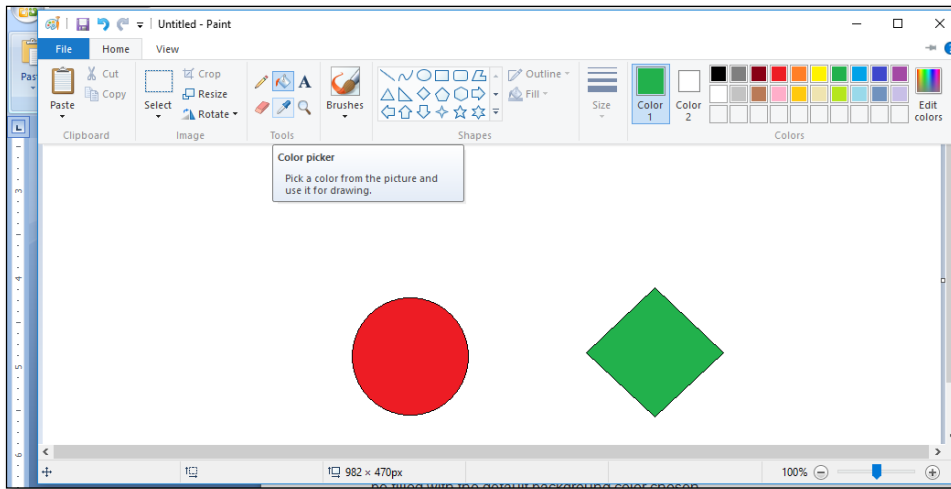

3. Bring the pointer to the Green Diamond to pick the green color. The shape of the pointer will change.
4. Now move the pointer inside the Red Circle and click once.
5. The color of the circle will change to green.

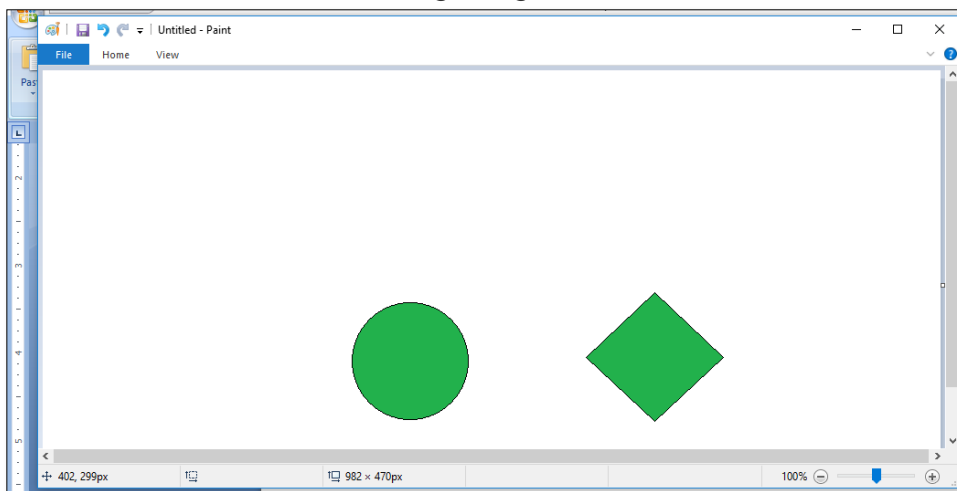

3. Eraser Tool

Rubber tool is used to erase the part of the picture. When you erase a portion it will be filled with the default background color chosen.

Follow these steps to use this tool

1. Select the Eraser tool from the tools group
2. Select the part of the image to be erased.

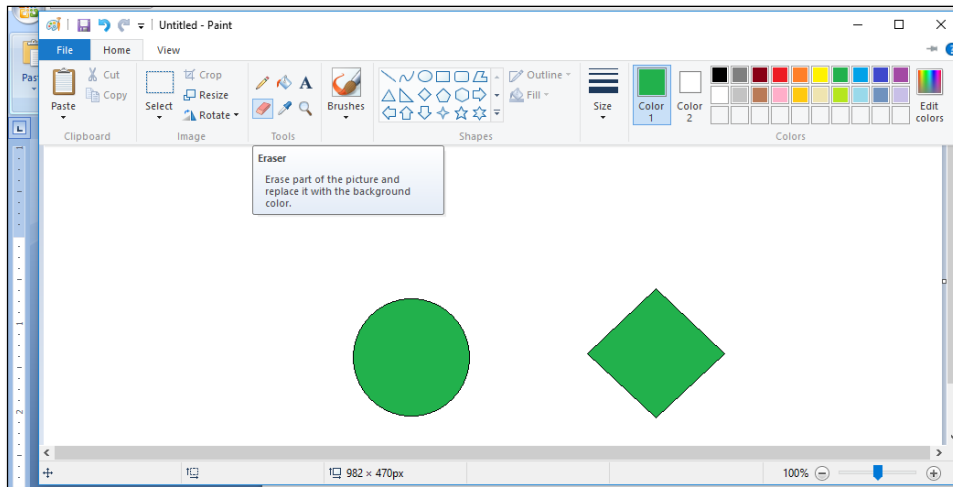

3. Drag the mouse over the image of which you want to erase the part by background color.
4. For example White eraser and Red eraser to erase the parts of circle and Diamond respectively.

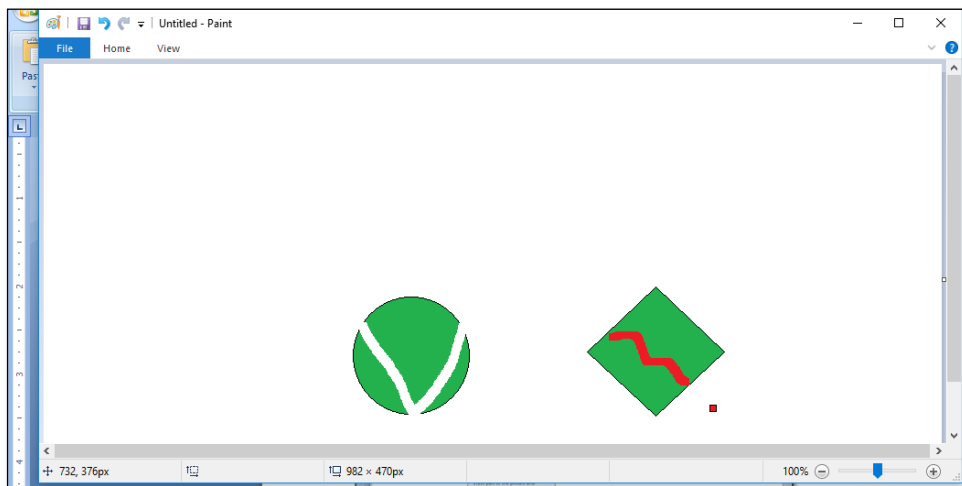

4. Pencil Tool

This tool is used to write the free hand text with selected background color.

Follow these steps to use this tool

1. Select the Pencil tool from the Tools group.
2. The Pencil tool will have default color
3. Click on the drawing area to use this tool.
4. Write the message you want to add. For example Circle and Diamond have been written on the drawing area with Red color.

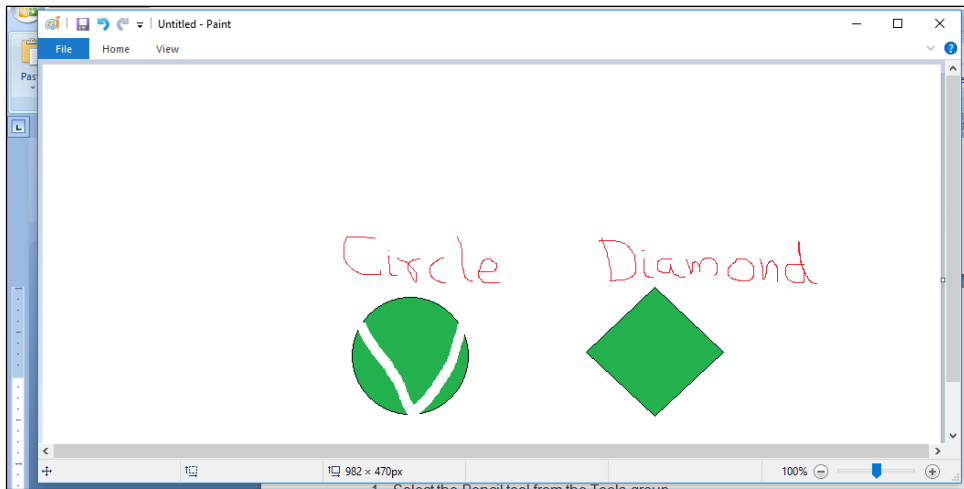

View Tab :

This is the Second Tab of MS Paint. It has three groups of related commands. Zoom, Show or hide and Display.

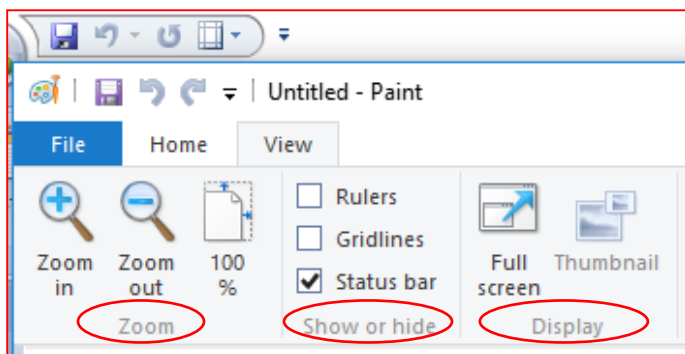

The View menu contains commands that are used to change the way the image or workspace are presented. These commands do not alter the image itself, only the way it is displayed.

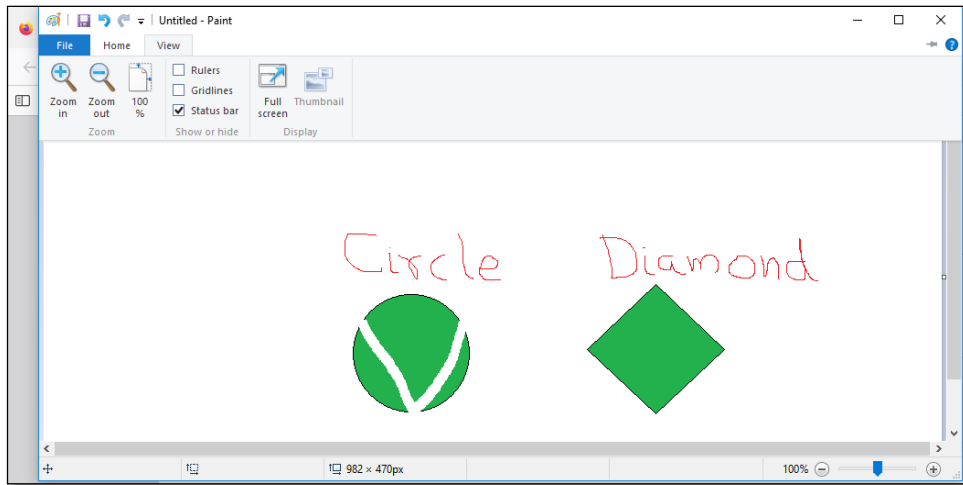

Zoom In

This zooms in on the image. This has the appearance of magnifying it. The amount of magnification is increased in fixed steps (e.g., 100%, 200%, 300%, etc.)



Zoom Out

This zooms out from the image. This has the appearance of reducing the image or viewing it from further away. The amount of zoom reduces in fixed steps. The amount of magnification is decreased in fixed steps (e.g., 100%, 50%, 25%, 12.5%....).

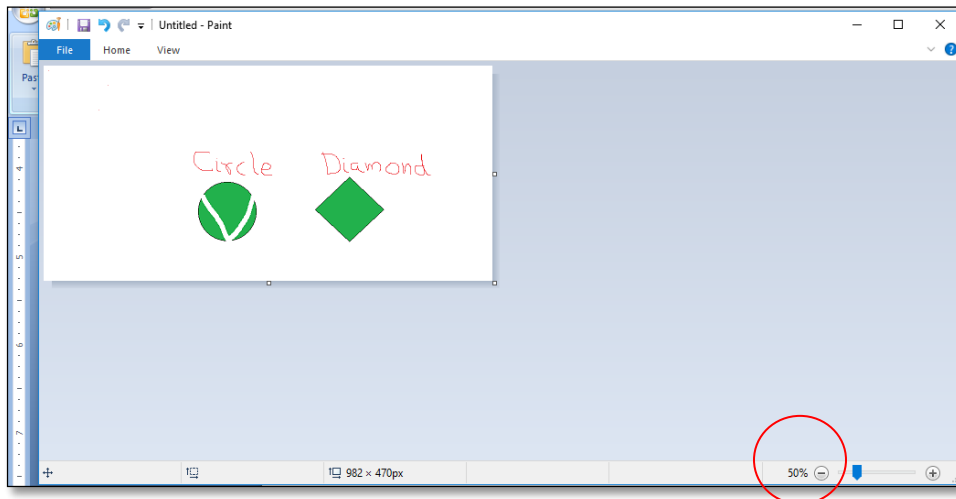

100 %

This sets the zoom level to 100%. Each pixel on the screen will correspond exactly with one pixel in the active layer.

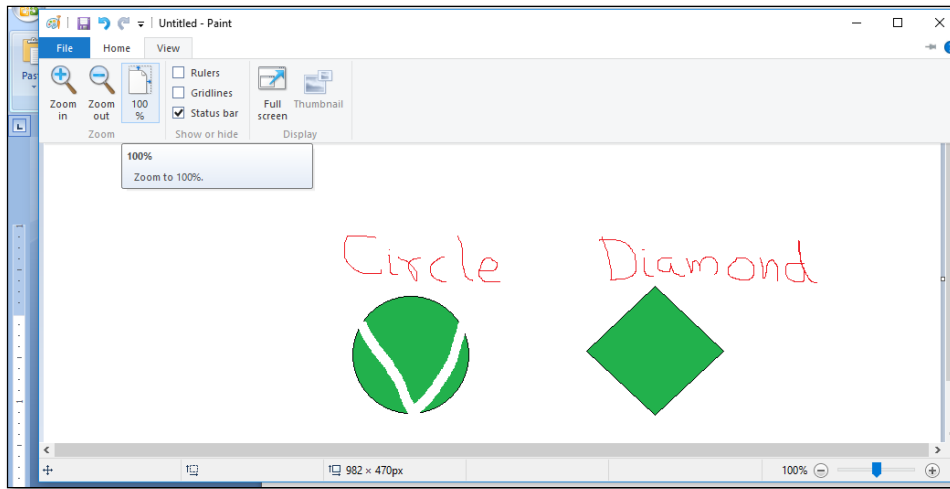

This command zooms the image to the limits of the Editing Window or to full size.

If the image is larger than the Editing Window at 100%, it will be reduced to fit within the Editing Window. If the image is smaller than the Editing Window at 100% it will be shown full size.

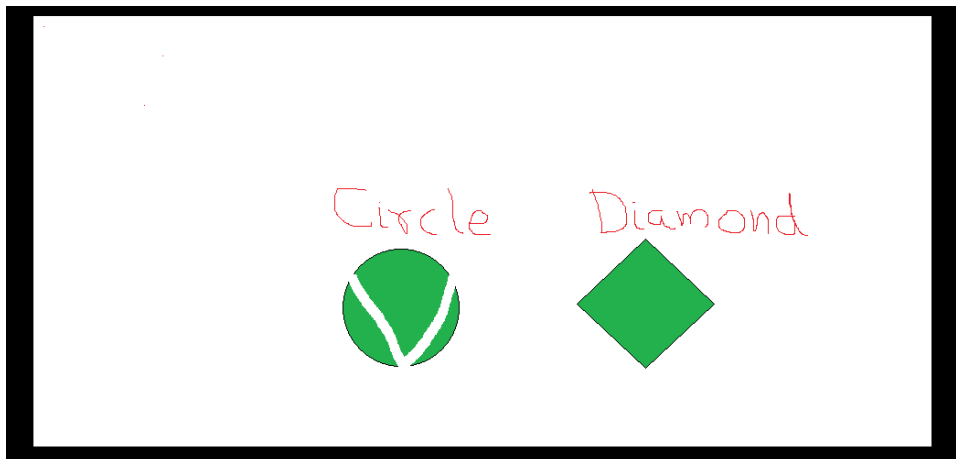

Shapes Group

MS-Paint shapes are used to create shapes. The shape tool includes 23 predefined shapes: six basic shapes, six polygon or star shapes, four arrows, three callout shapes, and two symbols. The various shapes can be selected from the shapes group.



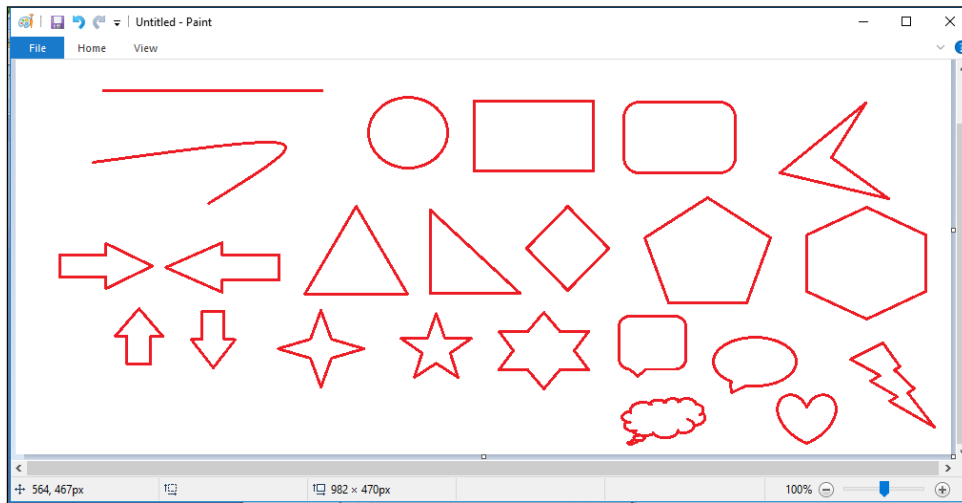

Outline and Fill Shapes

This tool is used to provide outline and fill any shape with different shades of colors. Some of the options available are

No fill , Solid Color, Crayon, Marker, Oil, Natural Pencil and Watercolor

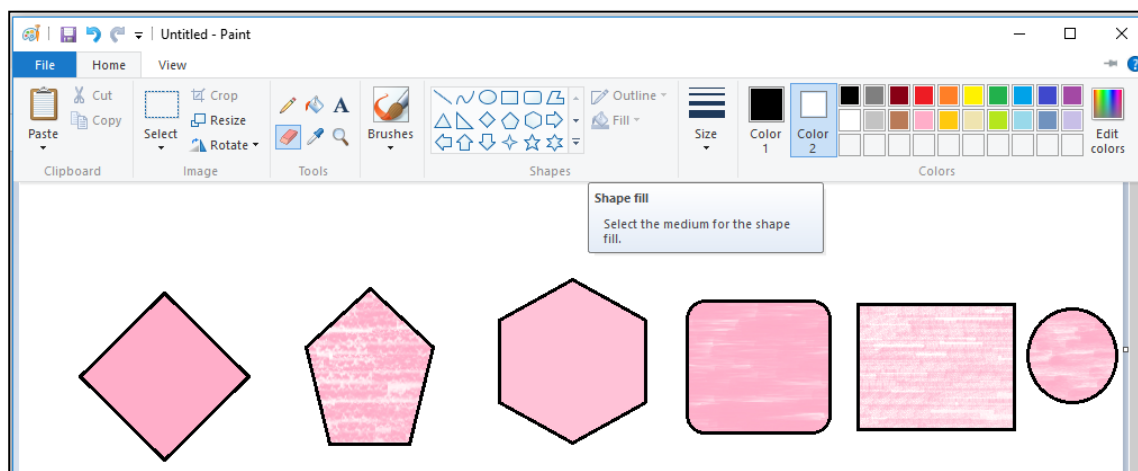

Solid Color Crayon Marker Oil Natural Pencil Watercolor

Colors In MS Paint

The Color section of the ribbon has three parts:

1. Boxes; showing the active colors-Color 1 and Color 2
2. The Color Palette
3. The Edit Colors button.

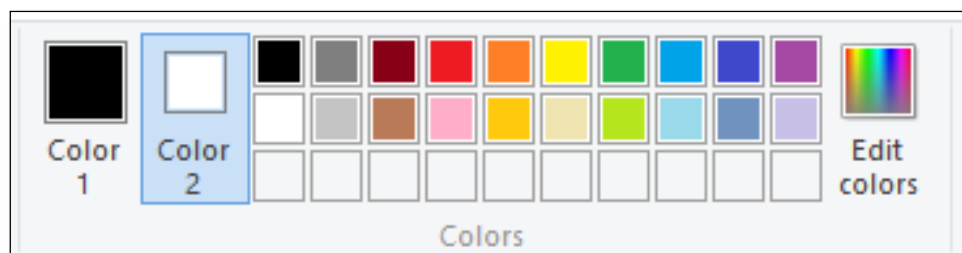

1. Color Box :

Color 1 : Color 1 is the Foreground Color and is always black when we open Paint.

Color 2 : Color 2 is the Background Color and is always white when we open Paint.

2. **The Color Palette** : The two top lines of the Color Palette show all the colors available. Whenever we are making a picture. The line of blank squares at the bottom shows those colors we have edited during our work. Once Paint is closed, the edited colors vanish away.

3. **Edit Colors** : The Edit Colors button takes us into the Edit Colors dialog box. We can click any color on an extended palette and click the Add to Custom Colors button. Here only one color will be added to the squares under the palette. To add more colors, we must return to the dialog box and add them one at a time.

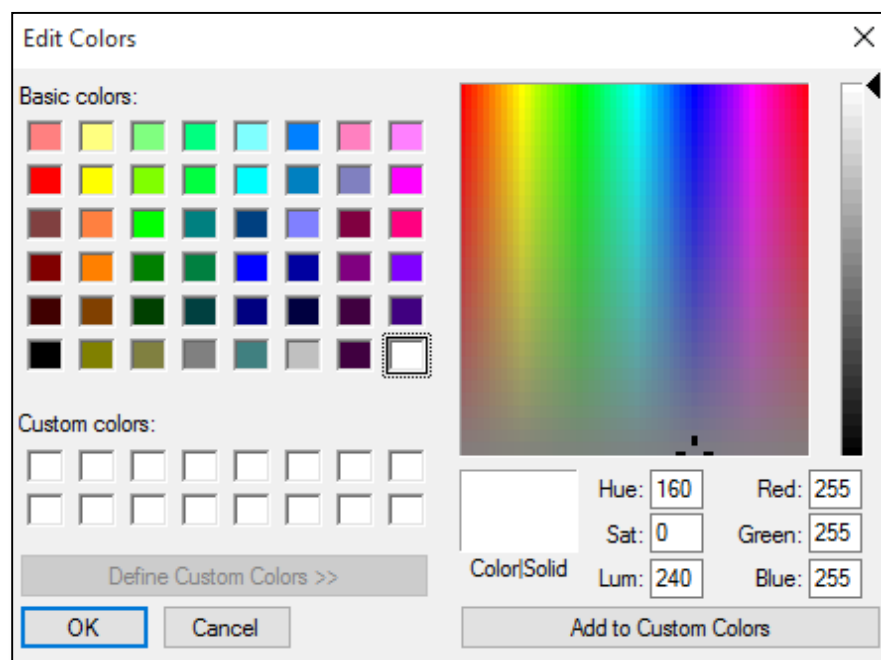

Projects –

During your practical classes, students can draw Design of a house, Scenery, school building, machine, cartoon character, etc.

EXCERISE

Q1. Fill in the blanks.

Erase, pencil tool, foreground, magnify

- 11) _____ Color and is always black when we open Paint.
- 12) Zoom in is used to _____ the image.
- 13) _____ is used to write the free hand text.
- 14) Rubber tool is used to _____ the part of the picture.

Q2. Answer the following questions.

1. Name any four drawing tools.
2. Describe the steps that you need to follow to type a text in paint.
3. Why do we use color picker tool?

Q3. Write 'T' for true and 'F' for false.

1. Home tab helps you to return to the home section of the document. _____
2. The shape tool includes 23 predefined shapes. _____
3. The Pencil tool do not have default color. _____
4. Background Color and is always black when we open Paint. _____

CHAPTER – 8

Programming with LOGO – Part 1

Learning Objectives

Students will be able to :

- Start LOGO
- Understand what a Turtle is
- Control the Turtle
- Change the color of the Pen
- Draw different trigonometric shapes



Hello Friends.

In this chapter, we are going to discuss about Programming using LOGO

Logo is a programming language that is very simple and easy to learn. The full form of LOGO is Language Of a Graphics Oriented. Logo was developed in the late 1960s at Bolt Beranek and Newman, Inc., in Cambridge, by W. Feurzeig, D. Bobrow and S. Papert. Its purpose was to teach children to program. Its main feature is that it provides simple commands for moving a "turtle" on a surface.

Why should we learn the Logo language?

- Because it is fun, lots of fun.
- Enhances the logical sense of the children.
- Develops programming skills.
- It is real Computer Science.
- Logo is a very easy and interesting programming language to learn. It has enough depth to virtually do anything, which can be done in any other computer programming language.

- Logo can be used to do the following tasks: 1. Draw figures 2. Type Text 3. Solve mathematical problems

How to download and install MSW Logo Software?

If Logo Programming Software is not installed on the computer, we can get it for free from the following link –

www.softronix.com/mswlogo.html

After installation, it puts Logo icon on the desktop of your computer.

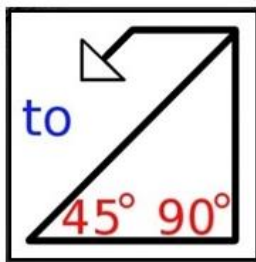

The MSW Logo screen has two parts –

- A Drawing window above with a triangle-shaped TURTLE in the center.
- A Commander window as shown in the following screenshot.

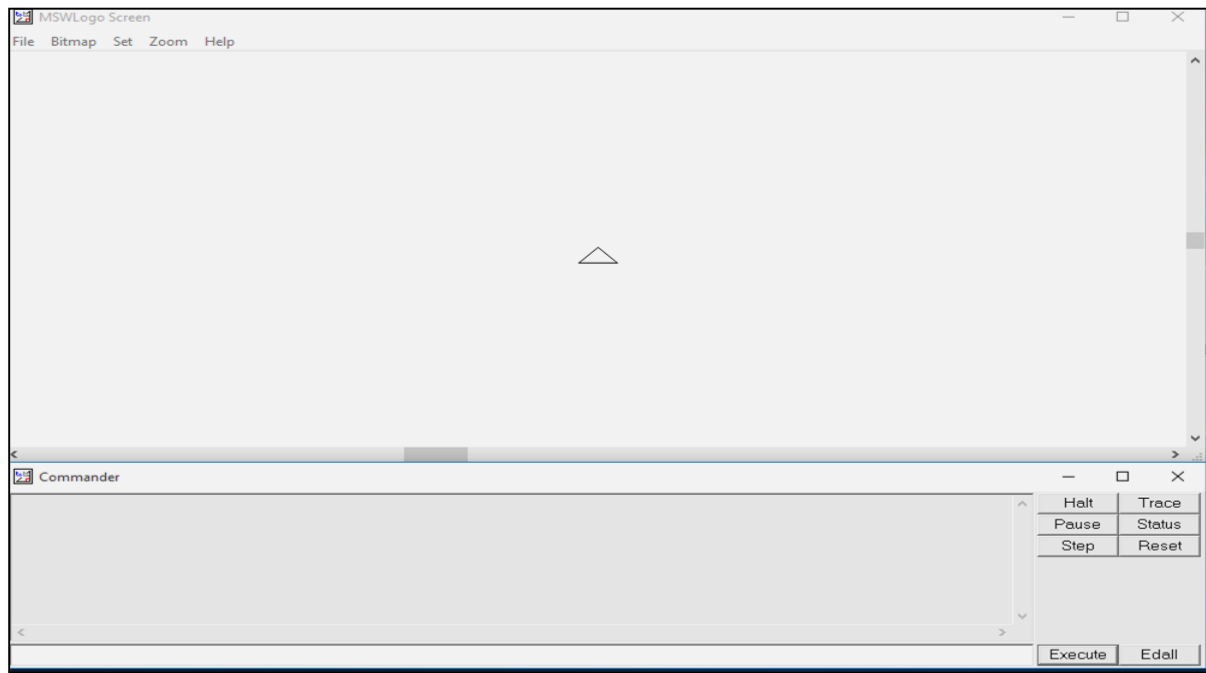

The Logo turtle has two parts 1) Head 2) Tail. The top pointed end of the turtle is called its head., whereas the wide base at the turtle's bottom is called its tail.

We write commands in the command line, i.e., the text box at the bottom of the Commander Window. These commands are called primitives.

The commander window is divided into three parts. 1. Command input box 2. Recall list box 3. Command Buttons. To execute or run these commands, press Enter or click the Execute Button.

Logo - Turtle

The simple Logo Drawing Commands move the Turtle forward and backward and also turn it right or left. LOGO language is not case sensitive. Command in uppercase or lowercase has same effect. The commands and their abbreviations are given below –

- fd – forward
- bk – backward
- rt – right turn
- lt – left turn
- cs – clearscreen

Except the cs command, each of these commands must be followed by one value called as its argument. The arguments for fd and bk are units; those of rt and lt are angles that can be any integer.

For example

FD 50 or Forward 50 means move the turtle 50 steps

BK 20 or back 20 means move the turtle 20 steps

RT 90 or Right 90 means move the turtle 90 degrees towards right

LT 90 or Left 90 means move the turtle 90 degrees towards left

CS means clear the screen

Let us try some of these commands and see their outputs

FD 50



FD 50 RT 90

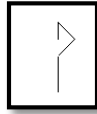

FD 50 RT 90 FD 50

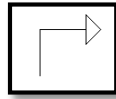

FD 50 RT 90 FD 50 LT 90

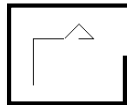

FD 50 RT 90 FD 50 LT 90 FD

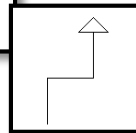

50

FD 50 RT 90 FD 50 LT 90 FD 50 RT 90 FD 50 RT 90 FD 250

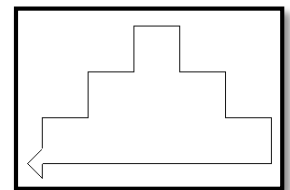

Logo - Controlling the Turtle & Pen

Logo has a number of other drawing commands, some of which are given below.

- **pd** – pendown
- **pu** – penup
- **ht** – hideturtle
- **st** – showturtle
- **setpensize**

The **pendown** and **penup** commands tell the turtle to leave ink on the screen as it moves or not to leave ink, respectively. The **hideturtle** and **showturtle** commands hide or show the turtle, but do not affect its ability to leave ink as it moves.

For example :

```
fd 50 penup fd 50 pendown fd 50 rt 90 fd 50 penup fd 50 pendown  
fd 50 rt 90 fd 50 penup fd 50 pendown fd 50 rt 90 fd 50 penup  
fd 50 pendown fd 50 hideturtle
```

Output :-

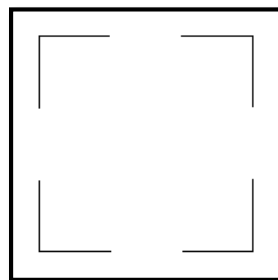

SETPENSIZE :This command allows you to increase or decrease the size of the pen

```
SETPENSIZE [2 2] FD 50 SETPENSIZE[3 3] RT 90 FD 50  
SETPENSIZE[4 4] RT 90 FD 50 SETPENSIZE[5 5] RT 90  
RT 180 FD 50 LT 90 SETPENSIZE[6 6] FD 50  
HIDETURTLE
```

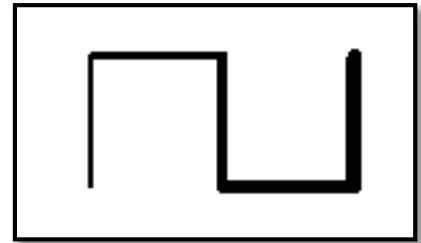

SETPENCOLOR

This command determines Pen color according to the number

```
CS SETPENCOLOR 1 FD 50 SETPENCOLOR 2 RT 90 FD 50 SETPENCOLOR 3 RT  
90 FD 50 SETPC 4 RT 90 FD 50
```

```
SETPENCOLOR 1 BLUE
```

```
SETPENCOLOR 2 GREEN
```

```
SETPENCOLOR 3 CYAN
```

```
SETPENCOLOR 4 RED
```

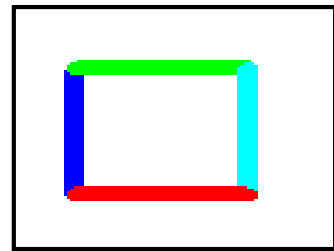

PENERASE

This command turns the turtle's pen into an eraser. When the turtle moves, it appears to erase by drawing in the current background color. To stop PENERASE, use PENDOWN, PENUP or SETPEN.

```
fd 50 setpensize[5 5] fd 50
```

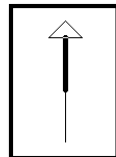

```
rt 180
```

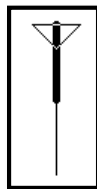

```
penerasefd 20
```

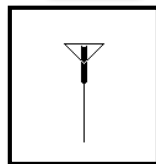

REPEAT

Let us try to draw a square

```
CS
```



```
fd 100rt 90fd 100rt 90fd 100rt 90fd 100rt 90
hideturtle
```

The output would be

We note that the two commands – fd 100 and rt 90 are repeated four times. Will it not be simpler to tell the computer that it should just repeat these two commands four times instead of writing them four times in a row? We can do exactly this, using the following command –

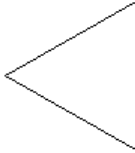
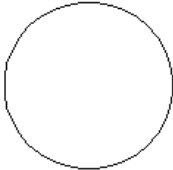
To draw a Square	
cs repeat 4[fd 100 rt 90] hideturtle	
To draw a Triangle	
cs repeat 3[fd 100 lt 120] hideturtle	
To draw a Circle	
cs repeat 36[fd 10 lt 360/36] hideturtle	

Draw Letters :- Let us try to draw some of the English letters

For example Letter A

```
cs
rt 13.5fd 200rt 148.5fd 200bk 100rt 108fd 55
```

Letter B

```
cs
rt 90 , repeat 180[fd 1 lt 1], rt 180, repeat 180[fd 1 lt 1] , lt 90 , fd 229
```

You can try other letters using Logo

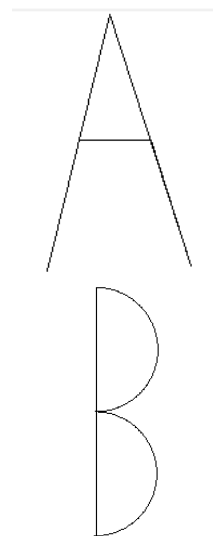

Hope, you must have learnt a bit of programming using LOGO

EXCERCISE

1. What is the full form of logo?
 2. What is the shape of a turtle?
 3. How many parts of logo windows?
 4. Name the two main parts of logo windows.
 5. How many parts of logo turtle?
 6. What is meant by head and tail of the turtle?
 7. What is another name of logo commands?
 8. Where do we type the commands?
 9. Who developed the MSW logo?
 10. from which website, we can download MSW logo?
 11. In how many parts the commander window is divided? Name them.
 12. Write the steps to start logo.
 13. Write the three uses of logo.
 14. Which command do we use to clear the screen?
 15. How can we make the turtle reappear on the screen?
- What is the meaning of bk 100 in Microsoft Windows Logo?
16. Write the command to draw a shape of square.
 17. Write the command to draw a star.
 18. Write the command to draw T-shape.
 19. Write commands to draw picture of Upward staircase (Steps).
 - 20 Write commands to draw English Letters E, H, K, L , O